

WLH2 Classe

MANUAL



Waterlogic Commercial Products, LLC
3175 Bass Pro Drive
Grapevine, TX 76051
(800) 288-1891 www.waterlogicdealers.com
Tech Portal Website: canteen-portal.waterlogic.com

WLH2 CLASSE MANUAL

Congratulations on your choice of the **Waterlogic WLH2 Classe Sparkling and Still Water Dispenser**. The **WLH2 Classe** model dispenses cold still water and cold sparkling water. Every **WLH2 Classe** includes:



Bio-Cote Anti-Microbial Protection



Firewall Advanced Purification



External Filter configuration can be optimized for all water conditions

The **WLH2 Classe** provides exceptional quality and great tasting water with every use.

INTRODUCTION

Carefully read and follow all instructions to ensure proper and efficient operation of your **WLH2 Classe Sparkling and Still Water Dispenser**. Contact your **Authorized Waterlogic Dealer** if you have any questions.

Waterlogic and **Authorized Waterlogic Dealers** employ trained service personnel who are experienced in the installation, function and repair of this equipment. This publication is written for use by these qualified individuals. **Waterlogic** encourages users to learn about products, however, we believe that product knowledge and service is best obtained by consulting your **Authorized Waterlogic Dealer**.

The **WLH2 Classe Sparkling and Still Water Dispenser** should be combined with selected water treatment components to create a system specifically tailored for each application by trained and qualified personnel.

Products manufactured and marketed by **Waterlogic** and its affiliates are protected by patents issued or pending in the United States and other countries.

Waterlogic reserves the right to change the specifications referred to in this literature at any time, without prior notice. Changes or modifications not expressly approved by **Waterlogic** could void the warranty and user's authority to operate the equipment.

TABLE OF CONTENTS

USER GUIDE

- Safety Alert Symbols 4
- Safety Precautions 4
- Features and Benefits 6
- Certifications 7
- Model Designations and General Specifications 8
- Electrical and Shipping Specifications 9
- Operating Instructions 10
- Volumetric Dispense Programming 11
- Warranty 12

SERVICE GUIDE

- Service Requirements 13
- Replacement Components (Consumables) 14
- Drawings and Parts List 15
- Flow Diagram 30
- Electrical Schematic 31

INSTALLATION GUIDE

- Pre-Installation Procedures 32
- Installation and Flushing Instructions 33
- Draining Procedure 36
- Adjusting the Gas Blend 37

SAFETY ALERT SYMBOLS

Read and follow all safety information carefully. The signal words used in this manual are selected as shown below and based on an assessment of the degree of potential injury or damage (severe or minor) and the occurrence of injury (definitely occurs or has the potential to occur) when the warning is ignored:

⚠ DANGER!

Indicates a situation which, when not avoided, results in death or severe injury.

⚠ WARNING!

Indicates a situation which, when not avoided, has the potential to result in death or severe injury; and/or severe property damage.

⚠ CAUTION!

Indicates a situation which, when not avoided, results or has the potential to result in minor injury; and/or minor property damage.

SAFETY PRECAUTIONS

Basic safety precautions should be followed, including the following:

Ensure all Local, State, and Federal Laws and Codes including health and safety guidelines are met when installing **Waterlogic** Equipment. Only qualified service technicians should attempt installation and service of **Waterlogic** Equipment. Always read the entire operating instructions before using the appliance and save these instructions for future use.

⚠ DANGER! *This product can cause death or severe injury if incorrectly operated, installed or maintained. The installation, maintenance, sanitizing and any repair must be performed by qualified persons trained by Waterlogic International or their approved distributors only. Do not remove any panel or cover to protect against electrical shock and exposure to UV radiation.*

⚠ DANGER! **ELECTRICAL SHOCK HAZARD.** *Always use a dedicated and properly grounded outlet. Unit should be protected by ground-fault circuit interrupter (GFCI) or residual current device (RCD) having a rated residual operating current not exceeding 30mA. Use only Waterlogic supplied power cord. Never use extension cords or power strips to connect unit. Do not use if the power supply cord is damaged. Always unplug from power supply prior to servicing.*

⚠ WARNING! **AUTHORIZED USE ONLY.** *This appliance is to be used for its intended purpose as described in this manual. Untrained individuals who use this manual assume the risk of any resulting property damage or personal injury. This appliance can't be used by children and persons with reduced physical, sensory or mental capabilities or lack of experience.*

⚠ WARNING! **UV-C EMITTER (UV LAMP).** *This appliance contains a UV-C emitter (UV Lamp). UV-C radiation may, even in small doses, cause harm to the eyes and skin. Unintended use or damage to the housing may result in the escape of dangerous UV-C radiation. Never operate the UV-C emitter if damaged or removed from enclosure. Do not touch or look directly into the faucet.*

- ⚠ WARNING! DO NOT OPERATE IF DAMAGED.** *Unplug and isolate water supply if abnormal conditions exist. Contact Waterlogic or authorized dealer for repair, service, and installation to avoid hazards.*
- ⚠ WARNING! CONNECT TO POTABLE WATER SUPPLY.** *This system is to be used for water only and is not intended for use where water is microbiologically unsafe or with water of unknown quality without adequate disinfection before or after the system.*
- ⚠ WARNING! TIP HAZARD.** *Dispenser could tip or fall causing serious injury. Always install unit on a firm, flat, and level surface and secure unit to cabinet, wall, or floor if needed. Never place heavy items on top of unit and never climb, stand, or hang on unit or storage cabinet to prevent injury and damage.*
- ⚠ WARNING! UNIT IS HEAVY. TWO PERSON LIFT REQUIRED.** *Transport unit empty and always use material handling equipment or two people with proper lifting technique to reduce injury risk.*
- ⚠ WARNING! STORE AND TRANSPORT UNIT EMPTY. ALWAYS SANITIZE BEFORE USE.** *The unit must be completely drained before storing to avoid stagnation and reduce microbiological contamination (potential bacterial growth). Always sanitize before use to eliminate any potential microbiological contaminants.*
- ⚠ CAUTION! INDOOR USE ONLY.** *Intended for Household Use. Never expose to direct sunlight, heat sources, or ambient air temperature above 37°C (100°F) or below 2°C (35°F). Install indoors and keep unit away from excessive humidity. Never expose to freezing temperatures. Ensure there is adequate clearance around the unit to allow refrigeration system condenser to dissipate heat. Warmer environments require more clearance around the unit. Minimum clearance around all surfaces of the machine is 2-inches. Installs where the ambient temperature exceeds 27°C (80°F), require a minimum of 4-inches clearance for proper heat dissipation and efficient operation.*
- ⚠ CAUTION! USE A WATER PRESSURE REGULATOR.** *Waterlogic will not be responsible for injury or damage caused by excessive water pressure. Input or feed pressure must be 40 psi to 60 psi. Be aware of any potential pressure surges caused by building/municipal pumping stations.*
- ⚠ CAUTION! USE UV STABILIZED SUPPLY LINES.** *Feed the unit with a potable ambient or cold water supply only. Feed water over 37°C (100°F) can damage the treatment components. Water block devices and external leak detectors are strongly recommended. Locate the unit as close to the water supply and the electrical connections as possible. Locate the unit as close to the water supply and the electrical connections as possible. Immediately isolate or close water supply valve and contact service representative if leak is noticed.*

Contact Waterlogic for assistance or help finding an Authorized Service Representative.

WLH2 CLASSE FEATURES AND BENEFITS

Sparkling and Still Cold Water

Counter Top and Cabinet Models come standard with Sparkling and Still Cold Water Selections to meet a wide range of customer demands. Cold Water Temperature is not adjustable.

Programmable Volumetric Dispense Settings

The **WLH2 Classe** is equipped with programmable volumetric dispense settings. Using the dispense buttons, preset volumes of water dispensed can be configured for each of the 4 dispense buttons.

Large Dispense Area with Adjustable (and Removeable) Drip Tray

12.25" from Faucet to drip tray allow for a wide range of water containers. The Drip Tray height can also be adjusted to accommodate for filling of standardized containers. The Drip Tray is also removeable to easily dump any water that has overflowed or spilled during dispense.

Firewall Advanced Purification

Firewall is a proprietary technology that places the UV lamp at the point of dispense. This point of dispense purification keeps the dispense nozzle free from external contamination as well as purifying the water, making the freshest water possible.

Ice Bath Drain Port

The **WLH2 Classe** is equipped with a drain port to the ice bath. This makes for easier maintenance as well to ease transport if needed.

Energy Saver

The **WLH2 Classe** comes from the factory with Energy Saver active. For the **Classe** to comply with Energy Star, the energy saver must come activated (ON) from the factory. When no buttons are pressed on the front user interface panel, the machine will automatically enter energy saver mode after 3 hours of inactivity, and the compressor cycle will be set to a 20 hour cycle. When any one of the front buttons are pressed while the system is in energy saver mode, the **Classe** will exit energy saver mode, and the compressor will enter its normal operation mode. Energy saver can be disabled/enabled by using the small black button on the back of the machine labeled "sleep mode". While sleep mode is inactive, the 4th LED (crescent moon) will NOT be lit. When it has entered energy saving mode, the 4th LED (crescent moon) will be lit.

CERTIFICATIONS

WLH2 Classes have been tested and certified to rigorous NSF and UL Standards. We believe that performance testing and certifications validate **Waterlogic** as a world-leader in water treatment systems.

Waterlogic WLH2 Classe Certifications Include



UL399 – Certified Drinking Water Cooler

Intertek Labs (ETL) Certified the **WLH2 Classe** to ANSI/UL 399 Standard for Drinking Water Coolers.

CSA C22.2 No. 120 CSA Standard for Refrigeration

Intertek



BPA Free - **Waterlogic** tests for BPA and declares that all of its products are Bisphenol-A FREE and contain no harmful BPA plastics.

NSF/ANSI-55 Class A – Ultraviolet Microbiological Water Treatment System

NSF / ANSI 372 – Drinking Water System Components – Lead Content

This Firewall System conforms to NSF/ANSI-55 Class A – Certified Drinking Water System Components, NSF / ANSI 372 – Drinking Water System Components for low Lead Content.



Waterlogic is certified to ISO 9001:2015 – Quality Management Systems (certified by Intertek). ISO 9001 is the internationally accepted standard for well managed organizations that have adopted the key quality management principles to its operations to bring consistent quality products and a culture of continuous improvement.



Safe Drinking Water Act

Waterlogic Water Treatment Systems conform to the Safe Drinking Water Act (SWDA) “lead-free” amendment effective January 4, 2014.

MODEL/PART DESIGNATIONS

BRAND NAME	DESCRIPTION	MODEL - PART NUMBER
<i>WLH2 Classe</i>	<i>WLH2 Classe</i> – Cold, Cold Sparkling	CLASSE WLH2
	F-H2FX-M-CS-IB-SB-WLU	
	Serial Number: TH2C434SBXXX	

SPECIFICATIONS

<u>ITEM</u>	<u>WHL2 CLASSE</u>
Water Connection	1/4" Quick Connect
Cold Water Temperature	Cold Water Temperature – Factory Set Point 5°C (41°F)
Sparkling Tank Capacity	1 Liter
Ice Bath Capacity	21 Liters
Recommended Service Pressure	43-60 psi (275-414 kPa) – Use Pressure Regulator
Recommended CO ₂ Service Pressure	50-60 psi (345-414 kPa) – Use Pressure Regulator
Rated Service Flow - Cold	2.0-3.0 Liters per Minute (0.5-0.8 Gallons per minute)
Rated Service Flow - Sparkling	2.5-3.5 Liters per Minute (0.6-0.9 Gallons per minute)
Environmental Temperature	16° - 32°C (60° - 90°F)
UV Lamp (per Firewall)	15 W
Refrigerant Gas	R134a, 110g, 3.88 ounces
R134a Pressures	High (230 psi), Low (90 psi)

SHIPPING SPECIFICATIONS

<u>ITEM</u>	<u>WHL2 Classe</u>
Width/Depth/Height	401mm(W) x 590mm(D) x 550mm(H) 15.79" x 23.25" x 21.65"
Width/Depth/Height w/ Wheels	401mm(W) x 590mm(D) x 607mm(H) 15.79" x 23.25" x 23.9"
Weight (dry)	48 kg (106 pounds)



ELECTRICAL SPECIFICATIONS

ELECTRICAL SUPPLY	120V/60Hz	15 Amp Service
COMPONENT	POWER (approximate)	AMP DRAW (approximate)
Pump	267w	2A
Fan	45w	0.5A
Mixing Motor	25w	0.3A
Control Power	30w	0.2A
Compressor	220w	2A
UV Lamp System	15w	0.6A
WHL2 Classe TOTAL	617w	5.6A

OPERATING INSTRUCTIONS



The WLH2 Classe utilizes a very simple user interface. 4 main buttons across the front user panel. The first two buttons (red/yellow) can be used to dispense cold Sparkling water and the last two (green/blue) are used to dispense cold Still water. Each of the buttons are programmed to dispense a preset volume of water and can be reprogrammed if desired.

- One quick push: Initiates dispensing of the preset volume of water. Will automatically shut off once preset volume is dispensed
- Push and hold: Initiates continuous dispensing of water until the button is released.
- Factory presets for the small and large dispense buttons are 750ml and 1000ml respectively.

The diagram below details the meaning and operational conditions of the LED panel located on the right side of the face of the machine.

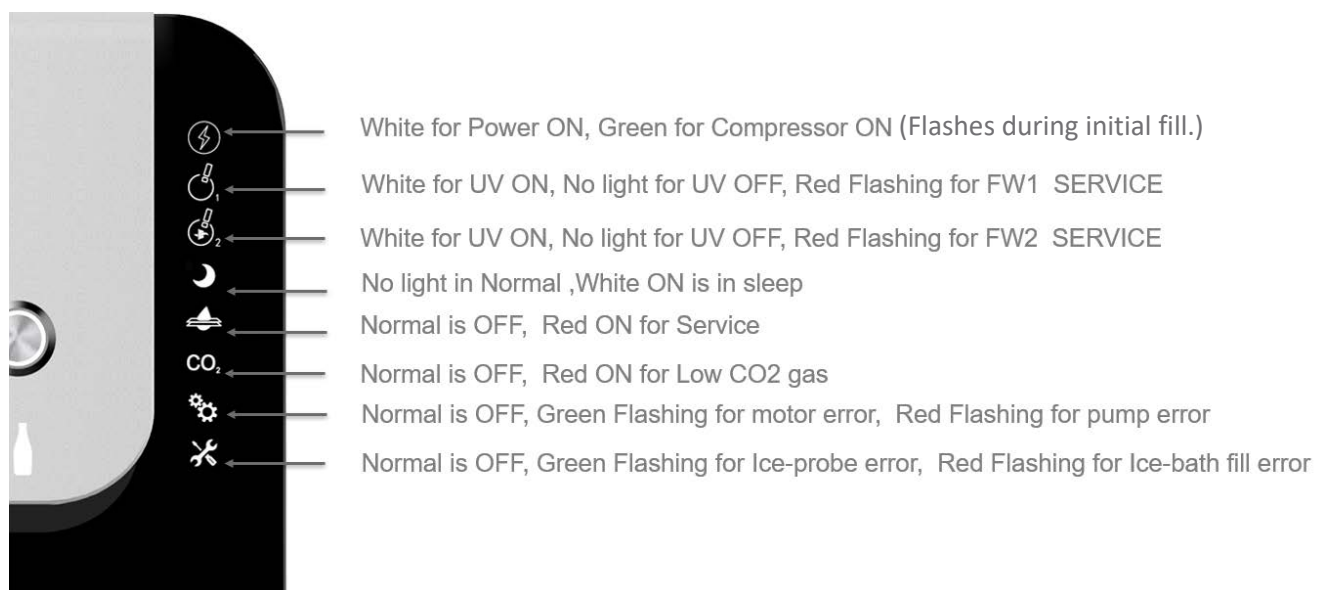

VOLUMETRIC DISPENSE PROGRAMMING

The WLH2 Firewall incorporates volumetric dispensing control. This allows a specific auto-dispensed volume of water to be preset for any of the 4 dispense buttons. The below steps explain how to program dispense of both cold and sparkling options. **IMPORTANT: Water must be dispensed to calibrate the preset, so have a container ready in the dispense area to catch this dispensed water.**

- Pre-set Sparkling or Still water volume: Press both dispense buttons simultaneously of either the sparkling or still buttons together for 5 seconds.
- Once programming mode is initiated, both sparkling button LED backlights will be flashing.
- With a container in the dispense ready to contain the water dispensed, give a short press and release of the dispense button you wish to preset. Water will begin to be dispensed.
- Once the desired amount of water has been dispensed, give the same button another short press and release to end dispensing.
- That button has now been preset to that specific volume of water.
- The two buttons for sparkling should still be flashing. At this time, the other button can now be preset for a different volume of water if desired using the same method, or the programming mode can be exited.
- To exit the setting mode, press both dispense buttons simultaneously for either sparkling or still water again for 5 seconds and the LEDs will return to solid light. (Maximum dispensing is 3liters.)

NOTE: Factory presets for the small and large dispense buttons are 750ml and 1000ml respectively.



WATERLOGIC MANUFACTURED WATER TREATMENT SYSTEM LIMITED WARRANTY **UNITED STATES AND CANADA ONLY**

Waterlogic water treatment systems are guaranteed to the original purchaser to be free of defects in materials and workmanship for a period of three (3) years from the date of purchase, but in no event longer than forty-eight (48) months from the date of manufacture. Waterlogic Commercial Products, LLC (“Waterlogic”) based in the U.S.A. and its affiliated companies are not liable for any cost of removal, installation, transportation, or any other charges which may arise in connection with a warranty claim.

This warranty does not cover damage or wear to products caused by abnormal operating conditions, accident, abuse, misuse, unauthorized or improper alteration or repair, damage caused by or resulting from shipping or accident, damage caused by hot water, freezing, flood, fire, or acts of God. The effects from chlorine corrosion, scaling and normal wear are specifically excluded from this warranty. This warranty does not cover products used outside the countries where the unit was purchased and does not cover products that were not installed in accordance with Waterlogic printed installation and operating instructions obtained in training or from www.waterlogic.us. Failure to follow all instructions for operation and maintenance voids the warranty. This warranty is not transferable.

To obtain warranty repairs or replacement, you must obtain a Return Authorization from Waterlogic. To obtain a Return Authorization, you must submit a Return Authorization form with supporting documentation to Waterlogic for evaluation. The form is available at www.waterlogic.us. Supporting documentation must include, but is not limited to; proof of purchase, installation date, failure date, and supporting installation and maintenance data. After you submit a Return Authorization form and supporting documentation, Waterlogic will determine whether a reasonably apparent defect in materials or workmanship covered by this limited warranty exists. If Waterlogic determines the claimed defect is covered by this warranty, Waterlogic will, at its sole discretion, determine whether to correct the defect or replace the unit, free of charge to you. If Waterlogic determines that the unit should be returned for warranty service, Waterlogic will approve of return in writing and will issue a Return Authorization which you must obtain prior to shipping the product. You are responsible for the cost of freight in to Waterlogic.

Waterlogic and its affiliated companies hereby limit the duration of any and all implied warranties to a maximum period of three (3) years from the date of purchase including, but not limited to, the implied warranties of merchantability and fitness for a particular purpose. Some states do not allow limitations on how long an implied warranty lasts, so the above limitation may not apply to you. Consequential and incidental damages are not recoverable under this warranty. Some states do not allow the exclusion or limitation of incidental or consequential damages, so the above limitation or exclusion may not apply to you.

This warranty gives you specific legal rights and you may also have other rights which may vary from state to state.

New Warranty Policy issued by Waterlogic Commercial Products LLC, USA - January 10, 2014

Waterlogic Commercials Products LLC
3175 Bass Pro Drive
Grapevine, TX 76051

Tel: (800) 288-1891
Website: waterlogic.us

SERVICE REQUIREMENTS

⚠ WARNING! *Read and understand the contents of this manual before attempting to service the WLH2 Classe. Failure to follow the instructions in this manual could result in death, serious personal injury, or severe property damage. Only trained and qualified technicians should attempt to install, maintain, or service Waterlogic Equipment.*

1. Visually inspect all electrical and water connections for signs of wear or damage.

⚠ DANGER! *HIGH VOLTAGE ELECTRICAL HAZARD. Unplug before inspection and service.*

2. **Waterlogic** recommends changing the UV Lamp every 12 months.

NOTE: When replacing the UV Lamp Assembly, the UV Lamp wiring harness must also be replaced.



UV Lamp Assembly Part #:
15-Watt Bulb 12-8310 (CT-2085)

UV Lamp Connectors

⚠ WARNING! *ULTRAVIOLET RADIATION. Protect your skin and eyes against ultraviolet rays. Never look directly at an operating UV light. Disconnect before removing UV Lamp.*

⚠ CAUTION! *UV LAMPS ARE HAZARDOUS. Lamps are considered Hazardous Waste and must be disposed of accordingly. Refer to Product MSDS sheet for details.*

⚠ CAUTION! *UV SYSTEM IS FRAGILE. Never handle the UV lamp or Quartz Sleeve with bare hands. UV Lamp and quartz sleeve must be free of oils and contaminants to ensure proper operation. Use a soft non-abrasive cloth to clean.*

3. Ensure there is adequate (minimum of 2") clearance around the **WLH2 Classe** and clean the condenser fins and compressor fan to provide efficient cooling system operation.
4. Sanitize the cold tank per instructions in the pre-installation procedures.

⚠ WARNING! *SANITIZER MAY CONTAIN HAZARDOUS CHEMICALS. Use of proper personal protective equipment such as rubber gloves and eye protection is required.*

5. Clean and sanitize external surfaces of the **WLH2 Classe**. Use soap and water or chemicals that are compatible with ABS plastic and will not damage or degrade the product surfaces.

REPLACEMENT COMPONENTS (CONSUMABLES)

Component	WLCP Part No.	Frequency of Replacement
UV Bulb, 15 Watts Assembly	12-2350	Every 12 months, or as required CT-2030-I00-00

⚠ CAUTION! Use only Waterlogic Replacement parts that can be obtained from *Waterlogic* or an *Authorized Waterlogic Dealer*, failure to do so will void the Warranty.

See Installation and Service Manual for additional information.

Surface Cleaning

Clean on a regular basis with damp lint free cloth. Never use harsh chemicals (alcohol or acid based) or abrasive agents on any part of the product to avoid damage. A mild cleaner such as Simple Green or equivalent is recommended.

DISPOSAL

End of Life

At the **end of this product's life**, ensure that it is disposed of in an environmentally friendly manner which is fully compliant **with all Federal/State/Local Requirements and Guidelines**. Do not dispose of this appliance with normal household or business waste.

WLH2 CLASSE DRAWING AND PARTS LIST

Wetted Drawing

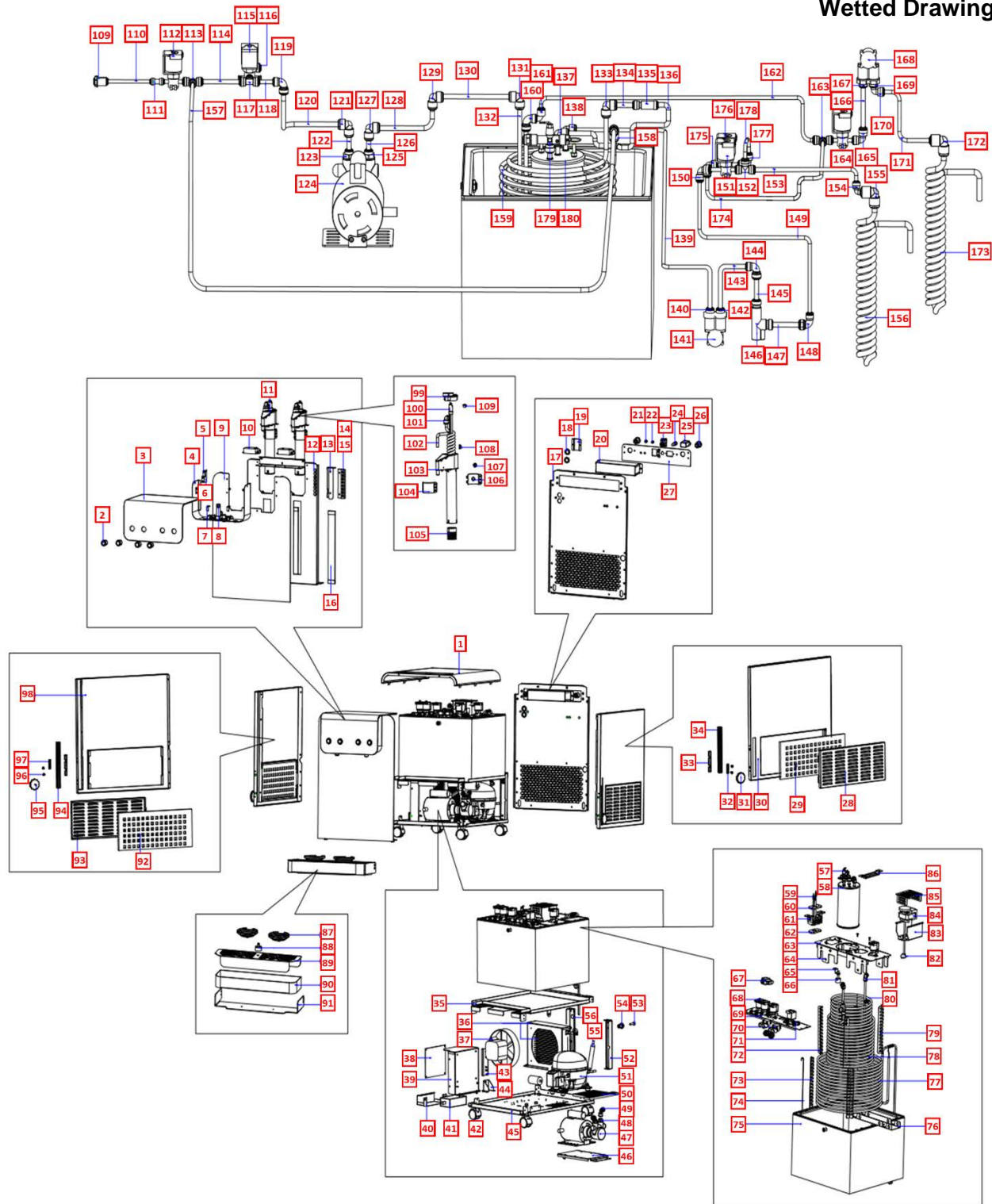

No	WLCP Part No.	Description	Picture
1	ST-0240-L00-00	Classe Top Cover	
2	EN-0098-L00-00	Metal Push Button	
3	ST-0273-L00-00	Classe Aluminum UI Panel with WL Logo	
4	ST-0241-L00-00	Classe UI Case	
5	EL-0174-L00-00	Micro Switch w/ Lever	
6	ST-0272-L00-00	Classe Micro Switch Cover	
7	ST-0267-L00-00	Classe UI Hinge Stopper	
8	PU-0027-L00-00	ODL Compensator	
9	PL-0243-L00-00	Classe Front Panel	
10	EN-0008-LA1-00	13W/15W 120V/60Hz Electronic FX Ballast	
11	N/A	HoReCa Firewall	
12	ST-0238-L00-00	Classe Front Panel	
13	ST-0260-L00-00	Classe LED PCB Bracket	

14	EN-0093-L00-00	Classe LED PCB Indicator	
15	PL-0267-L00-00	Classe LED PCB Shading Plate	
16	EN-0097-L00-00	Classe Back Light	
17	ST-0237-L00-00	Classe Back Panel	
18	PL-1293	Rubber O-ring for GF Side Panel Drain Hole	
19	ST-0326-L00-00	Classe Back Hole Cover	
20	ST-0246-L00-00	Classe Electric Cover	
21	EL-0206-L00-00	Classe Reset Filter Timer/Sleep Wire	
22			
23	EL-5004	Switch - Power (Red)	
24	EL-0021-L00-00	WL Cube Fuse 120V 15A with wire	
25	EL-5029	Socket for Plug Connection	
26	PU-4028	JG Bulkhead Connector Union 1/4" x 1/4"	
27	ST-0333-L00-00	Classe Back Electric Fixing Panel (USA)	

28	ST-0304-L00-00	Classe Louvered Side Window with SUS304-Right	
29	CS-0073-I00-00	Classe Air Filter	
30	ST-0306-L00-00	Classe Side Panel - Right - WL logo	
31	ST-0285-L00-00	Classe Side Panel Lock Knob – Right	
32	ST-0283-L00-00	Classe Rail Bracket Sample Short – Right	
33	ST-0281-L00-00	Classe Rail Bracket Sample Long	
34	ST-0280-L00-00	Classe Drip Tray Body Rail	
35	ST-0244-L00-00	Classe Ice Bath Bracket	
36	CO-0035-L00-00	Classe Micro Channel Condenser	
	ST-0302-L00-00	Classe Micro Channel Condenser Metal Case	
37	EN-0091-L00-00	Fan Motor and Blade 120V- M4Q045 -172/34	
38	EN-0092-L00-00	Classe Main Control PCB	
39	ST-0251-L00-00	Classe PCB Case	

40	ST-0259-L00-00	Classe Adaptor Bracket	
41	EL-0126-L00-00	GF MAX Adaptor	
42	CS-0089-L00-00	Lockable Wheel	
43	ST-0250-L00-00	Classe Fan Bracket 2	
44	ST-0249-L00-00	Classe Fan Bracket 1	
45	ST-0236-L00-00	Classe Base Plate	
46	ST-0262-L00-00	Classe Pump Bracket	
47	EN-0095-L00-00	Brass Vane Pump P201 and Pump Motor 120VAC	
48	PU-0024-I00-00	JG Straight Adaptor 8mm x 3/8" BSP	
49	PU-4089KR	Equal Elbow 5/16" x 5/16"	
50	CS-0093-L00-00	Classe Bottom Air Filter	
51	CO-0042-L00-00	LG Compressor 120V -CMA062LHCM	
52	ST-0248-L00-00	Classe Back Bracket – Right	

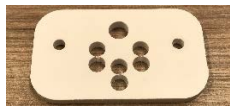





53	PU-4086	JG 1/4" Plug	
54	PU-4028	JG Bulkhead Connector Union 1/4" x 1/4"	
55	CO-9025	Domestic Filter Dryer (WL3000, WL950) 15.88*6.35*2.1(10g)	
56	ST-0247-L00-00	Classe Back Bracket – Left	
57	PU-0028-I00-00	Sparkling Safety Valve Kit	
58	CT-0040-I00-00	Classe Sparkling Tank	
59	CT-0028-L00-00	WL7 Ice Thickness Detection Probe	
60	PL-0245-L00-00	Classe Bracket for Ice Probe	
61	ST-0252-L00-00	Classe Ice Probe Bracket	
62	PL-0257-L00-00	Classe Bracket for Ice Probe Down	
63	ST-0255-L00-00	Classe Ice Bath Top Bracket	
64	PL-0244-L00-00	Classe Separating Plate for Cooling/Water Pipe	
65	ST-0268-L00-00	Classe water Float Bracket	





66	EN-0106-L00-00	Classe Water Level Float	
67	RO-0024	High Water Pressure Switch	
68	PU-0021-I00-00	MS DC Solenoid Valve SWV24-02 Terminal at Inlet	
69	ST-0261-L00-00	Classe Solenoid Valve Bracket	
70	EN-0096-L00-00	Gicar Flow Counter FMPL-F-L-G1/4 d.3.7	
71	PU-4011	JG Equal Tee Connector 1/4"	
72	ST-0257-L00-00	Classe Sparkling Pipe Fix Bracket	
73	ST-0258-L00-00	Classe Cooling Pipe Fix Bracket	
74	ST-0287-L00-00	Classe Cooling Pipe Fixing Pin	
75	PL-0246-L00-00	Classe Ice Bath Box	
76	ST-0270-L00-00	Classe Pipe Bottom Metal Separator	
77	CT-0038-I00-00	Classe SUS304 Gas Cooling Pipe	SEE DIAGRAM
78	CT-0037-I00-00	Classe SUS304 Water Cooling Pipe	SEE DIAGRAM

79	ST-0256-L00-00	Classe Cold Pipe Fix Bracket	
80	CT-0039-I00-00	Classe Sparkling Water Pipe	SEE DIAGRAM
81	PU-4089KR	Equal Elbow 5/16" x 5/16"	
82	PL-0256-L00-00	Classe Ice Bath Agitator Blade	
83	ST-0253-L00-00	Classe Agitator Bracket	
84	EN-0102-L00-00	ICE Bath Agitator 120V 187MM	
85	ST-0266-L00-00	Classe Agitator Safety Cover	
86	ST-0254-L00-00	Classe Sparkling Tank Bracket	SEE DIAGRAM
87	PL-0254-L00-00	Classe Bottle Guide	
88	PL-0281-L00-00	Drip Tray Floater Universal	
89	ST-0242-L00-00	Classe Drip Tray Grill	
90	ST-0243-L00-00	Classe Drip Tray Body	
91	ST-0263-L00-00	Classe Drip Tray Body support	

92	CS-0073-L00-00	Classe Air Filter	
93	ST-0303-L00-00	Classe Louvered Side Window with SUS304-Left	
94	ST-0280-L00-00	Classe Drip Tray Body Rail	
95	ST-0284-L00-00	Classe Side Panel Lock Knob - Left	
96	ST-0286-L00-00	Classe Drip Tray Support Bolt	
97	ST-0282-L00-00	Classe Rail Bracket Sample Short - Left	
98	ST-0305-L00-00	Classe Side Panel - Left - WL Logo	
99	CT-2088	WL200 Firewall UV Lamp Fixing Rubber	
100	CT-2085-LA0-00	15W LTFW XTM UV Lamp – 80	
101	PU-4137	JG 3/8" x 1/4" Reducing Fitting	
102	FW-0034-L00-00	HoReCa FW Spiral Quartz Sleeve	
103	FW-0044-L00-00	HoReCa FW Housing	
104	FU-0011	UVC Sensor Fixing Metal Bracket Brack	

105	FU-0010	UVC Sensor Fixing Metal Bracket w/ Tube	
106	CT-2089 EL-5146 PL-1358	UVC Sensor + Wire + Fixing Rubber	
107	FW-0040-L00-00	HoReCa FW Spiral Vibration Stop O-ring	
108	CT-2010	CDS Fixing Rubber	
109	PU-4028	JG Bulkhead Connector Union 1/4" x 1/4"	
110	PU-4031	JG LLD PE Tube - Blue O.D. 1/4"	
111	PU-4010	JG Equal Straight Connector 1/4"	
112	PU-0021-I00-00	MS DC Solenoid Valve SWV24-02 Terminal at Inlet	
113	PU-4011	JG Equal Tee Connector 1/4"	
114	PU-4031	JG LLD PE Tube - Blue O.D. 1/4"	
115	PU-0021-I00-00	MS DC Solenoid Valve SWV24-02 Terminal at Inlet	
116	PU-4008	JG Equal Elbow Connector 1/4"	
117	PU-4011	JG Equal Tee Connector 1/4"	

118	PU-4031	JG LLD PE Tube - Blue O.D. 1/4"	
119	PU-4007	JG Reducing Elbow Connector 5/16" x 1/4"	
120	PU-4014	JG LLDPE Tube - Blue 8mm Import	
121	PU-4089KR	JG Equal Elbow 5/16" x 5/16"	
122	PU-4014	JG LLDPE Tube - Blue 8mm Import	
123	PU-0024-I00-00	JG Straight Adaptor 8mm x 3/8" BSP	
124	EN-0095-L00-00	Brass vane Pump P201 and Pump Motor 120V AC	
125	PU-0024-I00-00	JG Straight Adaptor 8mm x 3/8" BSP	
126	PU-4014	JG LLDPE Tube - Blue 8mm Import	
127	PU-4089KR	JG Equal Elbow 5/16" x 5/16"	
128	PU-4014	JG LLDPE Tube - Blue 8mm Import	
129	PU-4089KR	JG Equal Elbow 5/16" x 5/16"	
130	PU-4014	JG LLDPE Tube - Blue 8mm Import	

131	PU-4089KR	JG Equal Elbow 5/16" x 5/16"	
132	CT-0039-I00-00	Classe Sparkling Water Pipe	SEE DIAGRAM
133	PU-4089KR	JG Equal Elbow 5/16" x 5/16"	
134	PU-4014	JG LLDPE Tube - Blue 8mm Import	
135	PU-0023-I00-00	JG Non-Return Valve 5/16"	
136	PU-4014	JG LLDPE Tube - Blue 8mm Import	
137	PU-4089KR	JG Equal Elbow 5/16" x 5/16"	
138	PU-4007	JG Reducing Elbow Connector 5/16" x 1/4"	
139	PU-4031	JG LLD PE Tube - Blue O.D. 1/4"	
140	PU-0025-I00-00	JG Straight Adaptor 1/4" x 1/4"	
141	EN-0096-L00-00	Gicar Flow Counter FMPL-F-L-G1/4 d.3.7	
142	PU-0025-I00-00	JG Straight Adaptor 1/4" x 1/4"	
143	PU-4031	JG LLD PE Tube - Blue O.D. 1/4"	

144	PU-4007	JG Reducing Elbow Connector 5/16" x 1/4"	
145	PU-4014	JG LLDPE Tube - Blue 8mm Import	
146	PU-0027-L00-00	ODL Compensator	
147	PU-4014	JG LLDPE Tube - Blue 8mm Import	
148	PU-4089KR	JG Equal Elbow 5/16" x 5/16"	
149	PU-4014	JG LLDPE Tube - Blue 8mm Import	
150	PU-4007	JG Reducing Elbow Connector 5/16" x 1/4"	
151	PU-0021-I00-00	MS DC Solenoid Valve SWV24-02 Terminal at Inlet	
152	PU-4011	JG Equal Tee Connector 1/4"	
153	PU-4031	JG LLD PE Tube - Blue O.D. 1/4"	
154	PU-4066	JG Stem Elbow Connector 1/4" x 1/4"	
155	PU-4137	JG 3/8" x 1/4" Reducing Fitting	
156	FW-0034-L00-00	HORECA FW Sprial Quartz Sleeve	

157	PU-4031	JG LLD PE Tube - Blue O.D. 1/4"	
158	PU-4007	JG Reducing Elbow Connector 5/16" x 1/4"	
159	CT-0037-I00-00	Classe SUS304 Water Cooling Pipe	SEE DIAGRAM
160	PU-4007	JG Reducing Elbow Connector 5/16" x 1/4"	
161	PU-4066	JG Stem Elbow Connector 1/4" x 1/4"	
162	PU-4014	JG LLDPE Tube - Blue 8mm Import	
163	PU-4011	JG Equal Tee Connector 1/4"	
164	PU-0021-I00-00	MS DC Solenoid Valve SWV24-02 Terminal at Inlet	
165	PU-4008	JG Equal Elbow Connector 1/4"	
166	PU-4031	JG LLD PE Tube - Blue O.D. 1/4"	
167	PU-0025-I00-00	JG Straight Adaptor 1/4" x 1/4"	
168	EN-0096-L00-00	Gicar Flow Counter FMPL-F-L-G1/4 d.3.7	
169	PU-0025-I00-00	JG Straight Adaptor 1/4" x 1/4"	

170	PU-4066	JG Stem Elbow Connector 1/4" x 1/4"	
171	PU-4031	JG LLD PE Tube - Blue O.D. 1/4"	
172	PU-4137	JG 3/8" x 1/4" Reducing Fitting	
173	FW-0034-L00-00	HORECA FW Spiral Quartz Sleeve	
174	PU-4031	JG LLD PE Tube - Blue O.D. 1/4"	
175	PU-4008	JG Equal Elbow Connector 1/4"	
176	PU-0021-I00-00	MS DC Solenoid Valve SWV24-02 Terminal at Inlet	
177	PU-4008	JG Equal Elbow Connector 1/4"	
178	PU-4031	JG LLD PE Tube - Blue O.D. 1/4"	
179	PU-0028-I00-00	Sparkling Safety Valve Kit	
180	CT-0040-I00-00	Classe Sparkling Tank	

WLH2 CLASSE WATER FLOW DIAGRAM

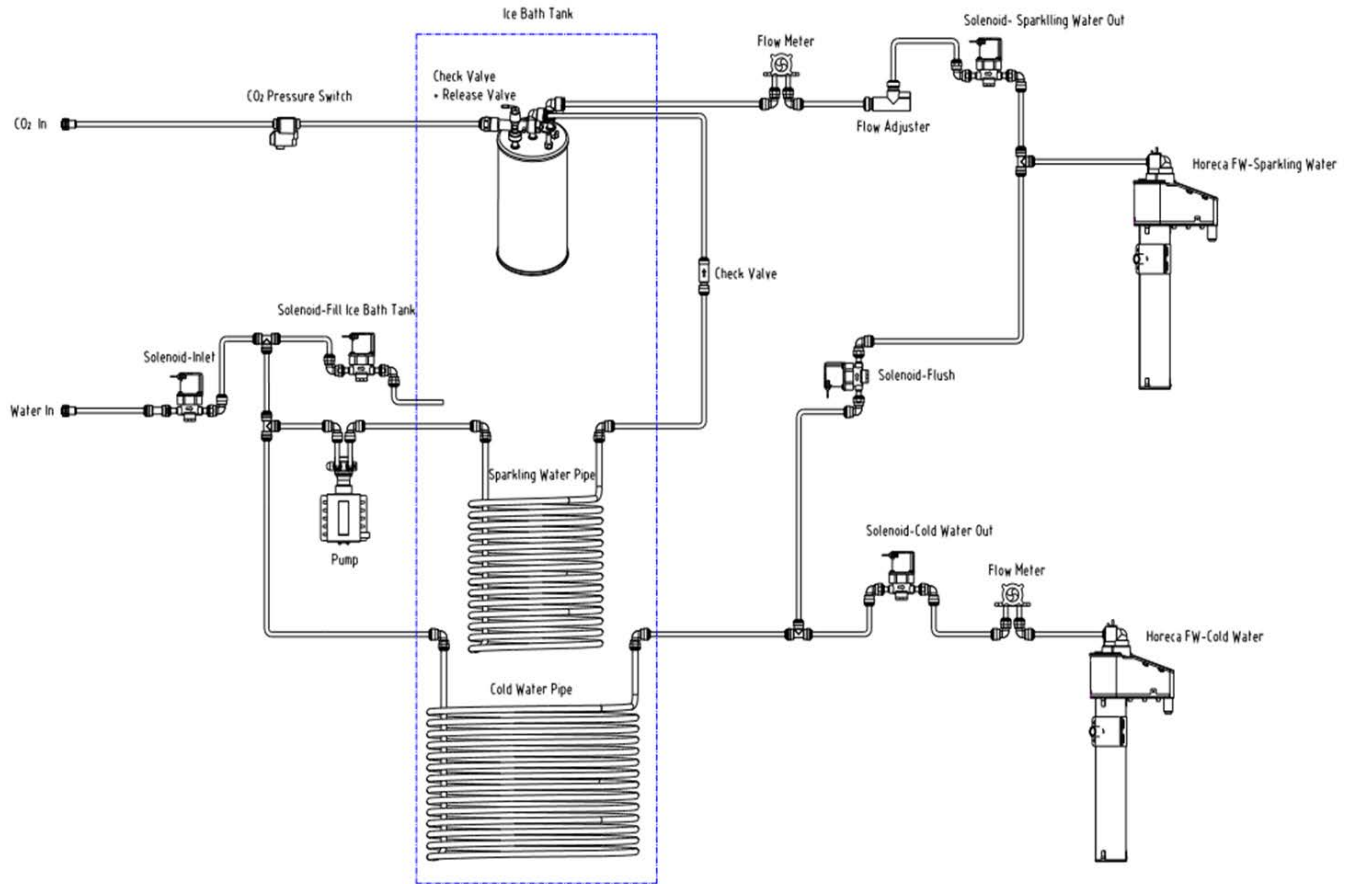

WLH2 CLASSE ELECTRICAL DIAGRAM

⚠ DANGER! HIGH VOLTAGE ELECTRICAL HAZARD. PCB (Printed Circuit Board) contains High Voltage. Only trained and qualified technicians should attempt live testing.

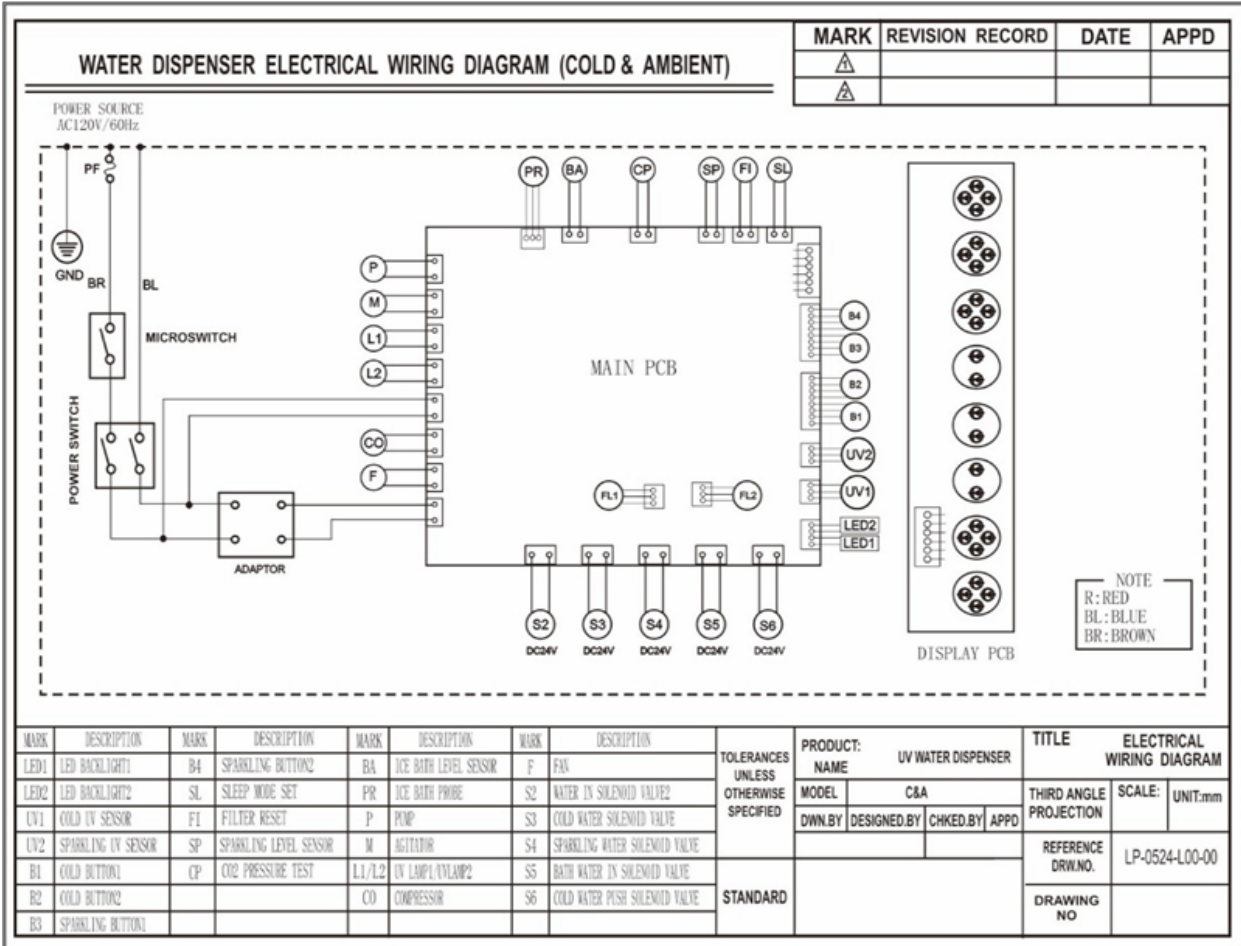

PRE-INSTALLATION PROCEDURES



DANGER! ELECTRICAL SHOCK HAZARD.

*Only qualified personnel who have read and understand this entire manual should attempt to install, or service this **WLH2 Classe**, failure to do so could result in death or serious injury. DO NOT plug into an electrical supply until specifically instructed.*



CAUTION! DRIP TRAY DRAIN.

If you intend to provide a drip tray drain for your customer, be aware that you will be called multiple times per month to service and unclog the tubing leading away from the drip tray to drain. Users will clog the drain with paper clips, erasers, napkins, tea bags, gum, and various other intended items. Waterlogic recommends you establish a minimum of weekly visits to the machine for cleaning of the drip tray drain.



WARNING! USE PROPER PERSONAL PROTECTIVE EQUIPMENT

Always ensure proper ventilation and use proper personal protective equipment such as gloves and eye protection when using chemicals. Refer to Material Safety Data Sheet for specific requirements of each chemical product. Take all necessary precautions to prevent sanitizer from contacting eyes, clothing, and any other surfaces in could damage (carpets).



DANGER! ELECTRICAL SHOCK HAZARD.

Do not plug in unit unless qualified. Only qualified personnel who have read and understand this entire manual should attempt to install or service this unit.

1. Remove the **WLH2 Classe** from the box, and place on the countertop or surface where it will be operated. Remove all cellophane wrapping from the machine. Perform a visual inspection of the unit for any damage or missing pieces.
2. Open the drip tray, remove the power cord and any accessories. Remove all cellophane wrapping, reassemble the drip tray and return to its position on the drip tray shelf.
3. Once the machine is in the desired position, lock the rolling wheels installed on the bottom of the machine to keep it in place. Do not install on an inclined surface.
4. Remove the bulkhead caps on the top two bulkhead connectors at the rear of the machine.

INSTALLATION AND FLUSHING PROCEDURES

Safety and Installation Guidelines

Ensure all Local, State, and Federal Laws and Codes including health and safety guidelines are met when installing **Waterlogic** Equipment. Only qualified service technicians should attempt installation and service of **Waterlogic** Equipment.

- ⚠ WARNING! ELECTRICAL SHOCK HAZARD.** *Always unplug (isolate from power supply) to prevent electrical shock except where electrical tests are specified.*
- ⚠ WARNING! IMPROPER SUPPLY OR CONNECTION CAN RESULT IN RISK OF SHOCK.** *Connect to a 15 amp, 120V 60Hz properly grounded outlet (GFI is recommended). Ensure polarity is correct and always use a 3-prong outlet. Consult a qualified electrician if you have any questions.*
- ⚠ WARNING! USE ONLY Waterlogic SUPPLIED POWER CORD.** *Locate system within 5 feet of power supply. Never use an extension cord or adapter. Do not use a damaged power cord or plug. Keep power cord out of heavy traffic areas and away from heat sources. Do not, under any circumstances, remove ground prong or alter the power cord. Never pull the power plug from the outlet with a wet hand or allow the plug to get wet. Failure to use the supplied power cord will void UL Certification and Warranty.*
- ⚠ CAUTION! INDOOR USE ONLY.** *Never expose to direct sunlight, heat sources, or ambient air temperature above 38°C (100°F) or below 2°C (35°F). Install indoors and keep unit away from excessive humidity. Never expose to freezing temperatures. Ensure there is adequate clearance around the unit to allow refrigeration system condenser to dissipate heat. Warmer environments require more clearance around the unit. Minimum clearance around all surfaces of the machine is 2-inches. Installs where the ambient temperature exceeds 80°F, require a minimum of 4-inches clearance for proper heat dissipation and efficient operation.*
- ⚠ CAUTION! USE A WATER PRESSURE REGULATOR.** *Waterlogic will not be responsible for injury or damage caused by excessive water pressure. Operating pressure must be 40 psi to 60 psi. Be aware any of potential pressure surges caused by building/municipal pumping stations.*
- ⚠ CAUTION! USE UV STABILIZED SUPPLY LINES.** *Feed the unit with a potable ambient or cold-water supply only. Feed water over 100° F (37°C) can damage the treatment components. Water block devices and external leak detectors are strongly recommended. Locate the unit as close to the water supply and the electrical connections as possible.*
- ⚠ WARNING! STORE AND TRANSPORT UNIT EMPTY. ALWAYS SANITIZE BEFORE USE.** *The unit must be completely drained and sealed before storing to avoid stagnation and reduce microbiological contamination (potential bacterial growth). Sanitize before use to eliminate any potential microbiological contaminants*

Pre-installation procedures as prescribed in this manual must be performed before installing the **WLH2 Classe**.

Always install indoors and place the **Waterlogic WLH2 Classe** on a firm, flat and stable surface.

1. Attach the water supply line to the 1/4" feed water inlet bulkhead fitting on the upper left section of the rear panel of the **WLH2 Classe**. **Waterlogic** requires the use of a water pressure regulator. Water feed pressure must be between 40-60 psi. Turn on the water supply and check for leaks.
2. Connect the upper right port to a food grade CO₂ gas supply, again using a 1/4" supply line. Open the tap of the gas bottle and set the pressure to 4 bar (50psi).



3. Check to ensure that the Red Compressor Power Switch is the *O=OFF* position.

NOTE: Switches have internal LED that illuminates when placed in *I=ON* position.



4. Connect the power cord to the back of the **Waterlogic WLH2 Classe** and to a 120 Volt supply. Turn Red Compressor Switch to the *I=ON* position to power the unit.
5. Water will begin filling the Ice Bath, which will take 4-5min. During this time the White Power indicator on the front UI panel should be blinking, communicating the unit is running its initial setup process.
6. Once the Ice bath has reached a suitable level (after 4-5min), the White Power indicator will light solid, and water can now be dispensed. **NOTE:** There is a 5 min delay after the indicator lights solid before the compressor begins to operate.
7. **PLACE A CONTAINER IN THE DISPENSE ARE TO CATCH WATER.** Dispense water from the Still and Sparkling dispense spouts, one after the other, by holding in either the small or large dispense button. For the Still dispense, nothing will come out for several seconds at first, as the lines are being filled with water. Water should begin flowing after several seconds. For the Sparkling dispense, the same process will occur, but there will also be some CO₂ gas release during the first few seconds of dispensing as well. Continue dispensing until a strong stream is achieved.

8. Dispense about 1 gallon of water from each line. This will sufficiently **FLUSH** the lines. Be sure to place a container under the spouts to collect the water from the flushing process.
9. If water supply is RO water (or if the TDS is less than 10ppm), a spoonful of sodium bicarbonate (baking soda) **MAY** need to be added to the water in the ice bath to raise the water's TDS to a level that the sensors can effectively operate in. **NOTE:** If TDS is too low, compressor will not cycle on.
10. Verify that the UV Lamp operates as expected. The light can be seen from the underside of the spout.
- ⚠ WARNING! ULTRAVIOLET RADIATION.** *Protect your skin and eyes against ultraviolet rays. Never look directly at an operating UV light. Always disconnect before removal.*
11. Move the **Waterlogic WLH2 Classe** into its final operating position. Be sure that a minimum of 2" clearance is maintained around both sides and the back of the **WLH2 Classe**.
12. This is important to allow proper airflow and heat exchange of refrigeration system.
13. Be sure to lock the adjustable feet of the **WLH2 Classe**. Never install on an incline.
14. When the **WLH2 Classe** has reached its Cold Temp Set Point Temperature, the compressor will cycle off.
15. Once the **WLH2 Classe** is at the target temperature, sample the water to ensure water meets expectations and additional rinsing or adjustment is not required.
16. Check the **WLH2 Classe** for any leaks. External Leak Protection is always recommended.
17. After about 45min to an hour, dispense about ½ gallon of water from the Sparkling side to rid the sparkling capsule of any lukewarm water. This will allow the Sparkling canister to regenerate with chilled water, creating a higher quality of sparkling water.
18. At this time, the volumetric auto-dispense settings can be configured. See page 11.

DRAINING INSTRUCTIONS

⚠ WARNING! STORE UNIT EMPTY. ALWAYS SANITIZE BEFORE REUSE.

The unit must be completely drained and sealed before storing to avoid stagnation and reduce microbial growth).

1. The **WLH2 Classe** has two main parts to drain, the Still/Sparkling water lines, and the Ice Bath. Draining instructions for both parts are below.
2. First, **SHUT OFF** the water supply to the machine.
3. Close the valve on the CO₂ bottle.
4. To drain the **WLH2 Classe** Ice Bath, remove the 1/4" plug, that is inserted into the drain bulkhead located on the rear of the machine. **Upon removal of the plug, water will begin draining from the ice bath. Have a container prepared to catch the water, or back the machine up to a sink or drain basin. This operation will take upwards of 20-30min to fully drain the ice bath.*

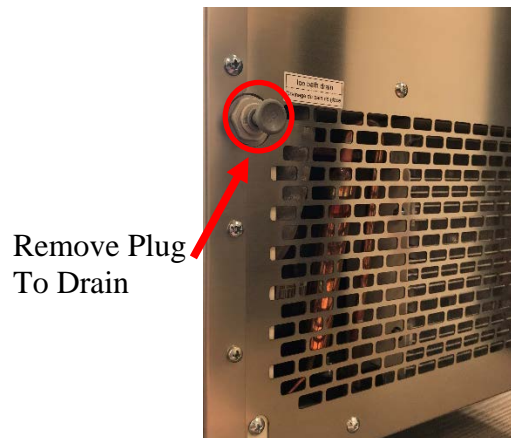

5. To drain the Still water line of the **WLH2 Classe**, (with the Gas Bottle shut off) disconnect the gas line from the CO₂ inlet. Disconnect the water supply line from the water inlet of the unit. Now plug the gas line into the water inlet of the unit and open the valve of the Gas Bottle. Simply hold one of the Still Water dispense button to drive water out of the still water line until it is empty, and gas is escaping. Shut off the valve of the Gas Bottle and reconnect to the CO₂ inlet of the unit. Once reconnected, do the same for the Sparkling Water line, holding the Sparkling dispense button until the dispense line is empty, and it begins to gas.
6. Turn the Red Compressor Switch to the **O=OFF** position immediately after draining the sparkling line.

ADJUSTING THE GAS BLEND

The gas blend for the Sparkling line can be adjusted if a sputtering or too much splash from the Sparkling dispense is experienced.

1. Locate the gas blend adjustment underneath the dispense nozzle panel, between the two nozzles.



2. Using a wide flathead screwdriver (NOT A PHILLIPS), turn the adjustment point clockwise to dial back the gas or counter-clockwise to increase the gas blend. Adjust until a smooth stream is achieved.