

WL100

MANUAL



Waterlogic Commercial Products, LLC
3175 Bass Pro Drive
Grapevine, TX 76051
(800) 288-1891 www.waterlogicdealers.com
Tech Portal Website: techportal.waterlogic.com

WL100 MANUAL

Congratulations on your choice of the **Waterlogic WL100 Water Treatment System**. The **WL100 Water Treatment System** dispenses cold, and hot. Every **WL100 Water Treatment System** includes:



Bio-Cote Anti-Microbial Protection



Filter configuration can be optimized for all water conditions

The **Waterlogic WL100 Water Treatment System** provides exceptional quality and great tasting water with every use.

INTRODUCTION

Carefully read and follow all instructions to ensure proper and efficient operation of your **WL100 Water Treatment System**. Contact **Waterlogic** or an **Authorized Waterlogic Dealer** if you have any questions.

Waterlogic and **Authorized Waterlogic Dealers** employ trained service personnel who are experienced in the installation, function and repair of **Waterlogic** equipment. This publication is written for use by these qualified individuals. **Waterlogic** encourages users to learn about products, however, we believe that product knowledge and service is best obtained by consulting **Waterlogic** or an **Authorized Waterlogic Dealer**.

Waterlogic Water Purification Systems should be combined with selected water treatment components to create a system specifically tailored for each application by trained and qualified personnel.

Products manufactured and marketed by **Waterlogic** and its affiliates are protected by patents issued or pending in the United States and other countries.

Waterlogic reserves the right to change the specifications referred to in this literature at any time, without prior notice. Changes or modifications not expressly approved by **Waterlogic** could void the warranty and user's authority to operate the equipment.

TABLE OF CONTENTS

USER GUIDE

- Safety Alert Symbols 4
- Safety Precautions 4
- Features and Benefits 6
- Certifications 7
- Model Designations and General Specifications 8
- Electrical and Shipping Specifications 9
- Operating Instructions 10
- Warranty 11

SERVICE GUIDE

- Service Requirements 12
- Hot Tank Principles of Operation 13
- Heater Circuit – Hot Tank Wiring 14
- Resetting the Hot Tank Overload (High Limit Safety) 15
- Hot Tank Descaling 17
- Adjusting Cold Water Set Point 19
- Programming – Disabling Energy Saving Sleep Mode 20
- Programming – Changing Hot Water Mode to Ambient 21
- Replacement Components (Consumables) 22
- Countertop Drawings and Parts List 23
- Tower Drawings and Parts List 29
- Flow Diagram 35
- Electrical Schematic 36

INSTALLATION GUIDE

- Pre-Installation Procedures 37
- Countertop Draining Procedure 41
- Tower Draining Procedure 43
- Installation Instructions 45

TROUBLESHOOTING GUIDE

- Power Troubleshooting 47
- Dispense Troubleshooting 50
- Cold Water Troubleshooting 63
- Hot Water Troubleshooting 64



SAFETY ALERT SYMBOLS

Read and follow all safety information carefully. The signal words used in this manual are selected as shown below and based on an assessment of the degree of potential injury or damage (severe or minor) and the occurrence of injury (definitely occurs or has the potential to occur) when the warning is ignored:

⚠ DANGER!

Indicates a situation which, when not avoided, results in death or severe injury.

⚠ WARNING!

Indicates a situation which, when not avoided, has the potential to result in death or severe injury; and/or severe property damage.

⚠ CAUTION!

Indicates a situation which, when not avoided, results or has the potential to result in minor injury; and/or minor property damage.

SAFETY PRECAUTIONS

Basic safety precautions should be followed, including the following:

Ensure all local, state, and federal laws and codes including health and safety guidelines are met when installing **Waterlogic** Equipment. Only qualified service technicians should attempt installation and service of **Waterlogic** Equipment. Always read the entire operating instructions before using the appliance and save these instructions for future use.

⚠ DANGER! *This product can cause death or severe injury if incorrectly operated, installed or maintained. The installation, maintenance, sanitizing and any repair must be performed by qualified persons trained by Waterlogic International or their approved distributors only. Do not remove any panel or cover to protect against electrical shock.*

⚠ DANGER! ELECTRICAL SHOCK HAZARD. *Always use a dedicated and properly grounded outlet. Unit should be protected by ground-fault circuit interrupter (GFCI) or residual current device (RCD) having a rated residual operating current not exceeding 30mA. Use only Waterlogic supplied power cord. Never use extension cords or power strips to connect unit. Do not use if the power supply cord is damaged. Always unplug from power supply prior to servicing.*

⚠ WARNING! AUTHORIZED USE ONLY. *This appliance is to be used for its intended purpose as described in this manual and untrained individuals who use this manual assume the risk of any resulting property damage or personal injury. This appliance can't be used by children and persons with reduced physical, sensory or mental capabilities or lack of experience.*

⚠ WARNING! DO NOT OPERATE IF DAMAGED. *Unplug and isolate water supply if abnormal conditions exist. Contact Waterlogic or authorized dealer for repair, service, and installation to avoid hazards.*

- ⚠ WARNING! HOT WATER.** *Unit produces Hot Water in excess of 80°C (175°F). Water above 52°C (125°F) can cause severe burns or scalding. Keep unauthorized people and children away from the unit to avoid accidental dispensing of hot water.*
- ⚠ WARNING! CONNECT TO POTABLE WATER SUPPLY.** *This system is to be used for water only and is not intended for use where water is microbiologically unsafe or with water of unknown quality without adequate disinfection before or after the system.*
- ⚠ WARNING! TIP HAZARD.** *Dispenser could tip or fall causing serious injury. Always install unit on a firm, flat, and level surface and secure the **WL100 Water Treatment System** to the base cabinet with the screw provided to lock the components together. Secure unit to cabinet, wall, or floor if needed. Never place heavy items on top of unit and never climb, stand, or hang on unit or storage cabinet to prevent injury and damage.*
- ⚠ WARNING! UNIT IS HEAVY. TWO PERSON LIFT REQUIRED.** *Transport unit empty and always use material handling equipment or two people with proper lifting technique to reduce injury risk.*
- ⚠ WARNING! STORE AND TRANSPORT UNIT EMPTY. ALWAYS SANITIZE BEFORE USE.** *The unit must be completely drained before storing to avoid stagnation and reduce microbiological contamination (potential bacterial growth). Always sanitize before use to eliminate any potential microbiological contaminants.*
- ⚠ CAUTION! INDOOR USE ONLY.** *Intended for Household Use. Never expose to direct sunlight, heat sources, or ambient air temperature above 37°C (100°F) or below 2°C (35°F). Install indoors and keep unit away from excessive humidity. Never expose to freezing temperatures. Ensure there is adequate clearance around the unit to allow refrigeration system condenser to dissipate heat. Warmer environments require more clearance around the unit. Minimum clearance around all surfaces of the machine is 2-inches. Installs where the ambient temperature exceeds 27°C (80°F), require a minimum of 4-inches clearance for proper heat dissipation and efficient operation.*
- ⚠ CAUTION! USE A WATER PRESSURE REGULATOR.** *Waterlogic will not be responsible for injury or damage caused by excessive water pressure. Input or feed pressure must be 40 psi to 60 psi. Be aware of any potential pressure surges caused by building/municipal pumping stations.*
- ⚠ CAUTION! USE UV STABILIZED SUPPLY LINES.** *Feed the unit with a potable ambient or cold water supply only. Feed water over 37°C (100°F) can damage the treatment components. Water block devices and external leak detectors are strongly recommended. Locate the unit as close to the water supply and the electrical connections as possible. Locate the unit as close to the water supply and the electrical connections as possible. Immediately isolate or close water supply valve and contact service representative if leak is noticed.*

Contact Waterlogic for assistance or help finding an Authorized Service Representative.

WL100 FEATURES AND BENEFITS

Ambient, Cold and Hot Water

Ambient, Cold and Hot Water Selections to meet a wide range of customer demands. Cold temperature is adjustable, and the hot water mode can be programmed to ambient.

High Volume Storage and Water Capacity

1.6 Liter (0.4 Gallon) Hot Tank and 2 Liters (0.5 Gallon) Cold Tank.

BioCote® Anti-Microbial Protection

Certain plastic, silicon, and painted surfaces surrounding the dispensing areas and drip tray are infused with an exclusive additive called BioCote®. BioCote® provides an effective barrier against microbes like bacteria and mold, which may cause odor or staining.



Recessed Faucet

BioCote® Faucet (Spigot) is recessed into unit to protect from cross contamination.

Large Dispense Area

21.6 cm (8.5 inch) dispense height to accommodate most cup and bottle sizes.

Child Safeguard

The **WL100 Water Treatment System** requires user to select and hold both Red Buttons to prevent accidental dispensing of hot water.

Energy Saving Sleep Mode

Energy saving sleep mode can be programmed to turn off heater after 3 hours of hot dispense inactivity yielding significant energy savings when unit is not in use.

Stainless Steel Tanks

Peace of mind drinking from high quality, sealed stainless steel reservoirs.

Advanced Filtration

The **WL100 Water Treatment System** Tower equipped with easy access filter mounting tray that allows dealers to optimize filter configuration for all water conditions.

High Capacity Removable Drip Tray

High Capacity Removable Drip Tray with BioCote® protection. Drip tray is two-piece for easy cleaning and comes configured with optional drain port.



WL100 CERTIFICATIONS

Waterlogic water treatment systems have been tested and certified to rigorous NSF and UL Standards. We believe that performance testing and certifications validate **Waterlogic** as a world-leader in water treatment systems.

WL100 Water Treatment System Certifications Include



Intertek

UL399 – Certified Drinking Water Cooler

Intertek Labs (ETL) Certified the **WL100 Water Treatment Systems** to ANSI/UL 399 Standard for Drinking Water Coolers.

CSA C22.2 No. 120 CSA Standard for Refrigeration.



BPA Free - **Waterlogic** tests for BPA and declares that all of its products are Bisphenol-A FREE and contain no harmful BPA plastics.



NSF/ANSI-61 – Certified Drinking Water System Components

The **WL100 Water Treatment System** has been tested and certified by The Water Quality Association (WQA) to NSF/ANSI-61, Section 9.



Energy Star Certified

The **WL100 Water Treatment System** has been tested and certified to the Energy Star, a US Environmental Protection Agency (EPA) program that helps our customers save money and protect our climate through superior energy efficiency.

Waterlogic is certified to ISO 9001:2015 – Quality Management Systems (certified by Intertek). ISO 9001 is the internationally accepted standard for well managed organizations that have adopted the key quality management principles to its operations to bring consistent quality products and a culture of continuous improvement.



Safe Drinking Water Act

Waterlogic water treatment systems conform to the Safe Drinking Water Act (SWDA) “lead-free” amendment effective January 4, 2014.

ADA Compliance

Waterlogic designs water systems to be ergonomic and meet the highest standards available while considering use by disabled and physically impaired users. See our ADA Position Statement for future details.

MODEL/PART DESIGNATIONS

BRAND NAME	DESCRIPTION	MODEL - PART NUMBER
WL100 Counter Top	Waterlogic WL100 Counter Top - Cold and Hot	12-CHCM
	F-100-M-HC-TT-CS-WLU	
	Serial Number Prefix: 59 or GA1H216CS	
WL100 Tower	Waterlogic WL100 Tower - Cold and Hot	12-CHC
	F-100-FS-HC-TT-CS-WLU	
	Serial Number Prefix: 60 or GA2H216CS	

SPECIFICATIONS

<u>ITEM</u>	<u>WL100 Counter Top</u>	<u>WL100 Tower</u>
Cold Water Temperature	Cold Water Temperature – Factory Set Point 5°C (41°F) Adjustable to 1.1° - 12.2°C (34° - 54° F)	
Cold Tank Size	2 Liter (0.5 Gallons)	
Hot Water Temperature	85°C (185° F) Factory Set Point	
Hot Water Manual Reset Overload	105°C (221° F)	
Hot Tank Size	1.6 Liter (0.4 Gallons)	
Recommended Service Pressure	40-60 psi (275-414 kPa) – Always Use Pressure Regulator	
Maximum Service Pressure	100 psi (689 kPa). Always Use 40-60 Pressure Regulator to Prevent Damage	
Rated Service Flow	1.89 Liters per minutes (0.5 gallons per minute)	
Feed Water Temperature	37°C (100°F) Maximum Water Feed. Cold Water Supply Recommended	
Environmental Temperature	2°C to 37°C (35°F to 100°F). Indoor Use Only	
Water Connection	¼" Quick Connect	
Heater	500 W	
Refrigerant Gas	R134a, 40g, 1.41 ounces	R134a, 45g, 1.59 ounces
R134a Pressures	High (230 psi), Low (90 psi)	

WL100 DIMENSIONS AND WEIGHTS

<u>ITEM</u>	<u>WL100 Counter Top</u>	<u>WL100 Tower</u>
Width/Depth/Height	34cm x 41cm x 45cm (13.5" x 16" x 17.75" #)	34cm x 41cm x 103cm (13.5" x 16" x 40.5")
Weight (dry)	15.6 kg (34.4 pounds)	19.5 kg (43 pounds)

#WL100 Counter Top is 17.75 in. tall and may not fit between countertops and cabinets - Check installation to ensure adequate clearance.



SHIPPING SPECIFICATIONS

<u>ITEM</u>	<u>WL100 Counter Top</u>	<u>WL100 Tower</u>
Width/Depth/Height	38 cm x 45 cm x 46.5 cm (15" x 17.75" x 18.25)	38 cm x 45 cm x 106 cm (15" x 17.75" x 41.5")
Weight (dry)	18 kg (39.7 pounds)	23 kg (50.7 pounds)

ELECTRICAL SPECIFICATIONS

<u>ELECTRICAL SUPPLY</u>	<u>120V/60Hz, 1PH</u>	<u>15 Amp Service</u>
<u>COMPONENT</u>	<u>POWER (approximate)</u>	<u>AMP DRAW (approximate)</u>
Heater	500	4.2 Amps
Compressor	168	1.4 Amps
WL100 TOTAL	668	5.6 Amps

OPERATING INSTRUCTIONS

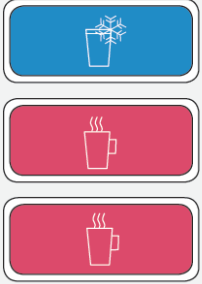

The above picture shows front LCD Display and Control Panel for the **Waterlogic WL100 Water Treatment System**.

For Cold Water	Press the Blue - Cold Water Select Button	<div style="text-align: center;">HOT AND COLD MACHINE</div> 
For Hot Water	Press the two Red - Hot Water Select Buttons at the same time. <i>This is a Safety Feature to prevent accidental dispensing of hot water.</i>	



WATERLOGIC MANUFACTURED WATER TREATMENT SYSTEM LIMITED WARRANTY **UNITED STATES AND CANADA ONLY**

Waterlogic water treatment systems are guaranteed to the original purchaser to be free of defects in materials and workmanship for a period of three (3) years from the date of purchase, but in no event longer than forty-eight (48) months from the date of manufacture. Waterlogic Commercial Products, LLC ("Waterlogic") based in the U.S.A. and its affiliated companies are not liable for any cost of removal, installation, transportation, or any other charges which may arise in connection with a warranty claim.

This warranty does not cover damage or wear to products caused by abnormal operating conditions, accident, abuse, misuse, unauthorized or improper alteration or repair, damage caused by or resulting from shipping or accident, damage caused by hot water, freezing, flood, fire, or acts of God. The effects from chlorine corrosion, scaling and normal wear are specifically excluded from this warranty. This warranty does not cover products used outside the countries where the unit was purchased, and does not cover products that were not installed in accordance with Waterlogic printed installation and operating instructions obtained in training or from www.waterlogic.us. Failure to follow all instructions for operation and maintenance voids the warranty. This warranty is not transferable.

To obtain warranty repairs or replacement, you must obtain a Return Authorization from Waterlogic. To obtain a Return Authorization, you must submit a Return Authorization form with supporting documentation to Waterlogic for evaluation. The form is available at www.waterlogic.us. Supporting documentation must include, but is not limited to; proof of purchase, installation date, failure date, and supporting installation and maintenance data. After you submit a Return Authorization form and supporting documentation, Waterlogic will determine whether a reasonably apparent defect in materials or workmanship covered by this limited warranty exists. If Waterlogic determines the claimed defect is covered by this warranty, Waterlogic will, at its sole discretion, determine whether to correct the defect or replace the unit, free of charge to you. If Waterlogic determines that the unit should be returned for warranty service, Waterlogic will approve of return in writing and will issue a Return Authorization which you must obtain prior to shipping the product. You are responsible for the cost of freight in to Waterlogic.

Waterlogic and its affiliated companies hereby limit the duration of any and all implied warranties to a maximum period of three (3) years from the date of purchase including, but not limited to, the implied warranties of merchantability and fitness for a particular purpose. Some states do not allow limitations on how long an implied warranty lasts, so the above limitation may not apply to you. Consequential and incidental damages are not recoverable under this warranty. Some states do not allow the exclusion or limitation of incidental or consequential damages, so the above limitation or exclusion may not apply to you.

This warranty gives you specific legal rights and you may also have other rights which may vary from state to state.

New Warranty Policy issued by Waterlogic Commercial Products LLC, USA - January 10, 2014

Waterlogic Commercials Products LLC
3175 Bass Pro Drive
Grapevine, TX 76051

Tel: (800) 288-1891
Website: waterlogic.us

SERVICE REQUIREMENTS

⚠ WARNING! *Read and understand the contents of this manual before attempting to service WL100 Water Treatment System. Failure to follow the instructions in this manual could result in death, serious personal injury, or severe property damage. Only trained and qualified technicians should attempt to install, maintain, or service Waterlogic Equipment.*

1. Visually inspect all electrical and water connections for signs of wear or damage.

⚠ DANGER! **HIGH VOLTAGE ELECTRICAL HAZARD.** *Unplug before inspection and service.*

2. Ensure there is adequate (minimum of 5 cm – 2 inches) clearance around the unit and clean the Condenser Grill and Compressor fan to provide efficient cooling system operation.
3. Sanitize the Cold Tank per instructions in the pre-installation procedures.
4. Clean and sanitize external surfaces of the unit. Use soap and water or chemicals that are compatible with ABS plastic and will not damage or degrade the product surfaces.
5. Remove and clean the Faucet. Replace as needed.

⚠ WARNING! **SANITIZER MAY CONTAIN HAZARDOUS CHEMICALS.** *Use of proper personal protective equipment such as rubber gloves and eye protection is required.*

HOT TANK PRINCIPLES OF OPERATION

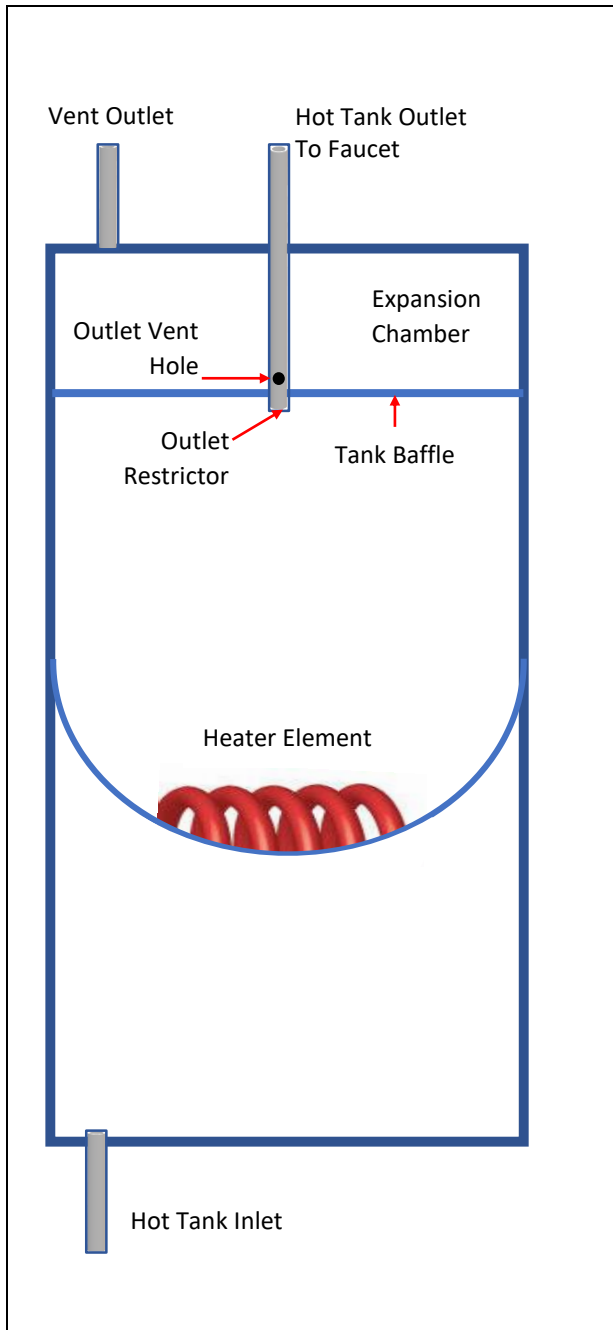

All **Waterlogic** Hot Tanks have a built in Vent or Expansion Chamber in the top of the tank except for WL270 (GF) units.

The Vent Chamber allows for expansion of the water when it is heated.

The chambers are separated by a welded-in tank baffle.

Water always flows into the bottom of the tank and out the top to the faucet.

The Hot Tank outlet tube has a restrictor in its base. This ensures the reservoir is always full by allowing more water in than out.

There is a small hole in the side of the tank outlet tube that allows air and water to pass into the vent chamber as it is heated.

Water in the vent chamber is suctioned back through the outlet tube vent hole when water is dispensed.

Expansion of water as it is heated in the reservoir will push the water out the faucet when the outlet tube vent hole becomes plugged with debris or scale.

The small Outlet Vent Hole is susceptible to scale build up and is a key indicator that descaling is required.



It is critical to descale the Hot Tank through the vent line and outlet line on a regular basis to prevent this problem.



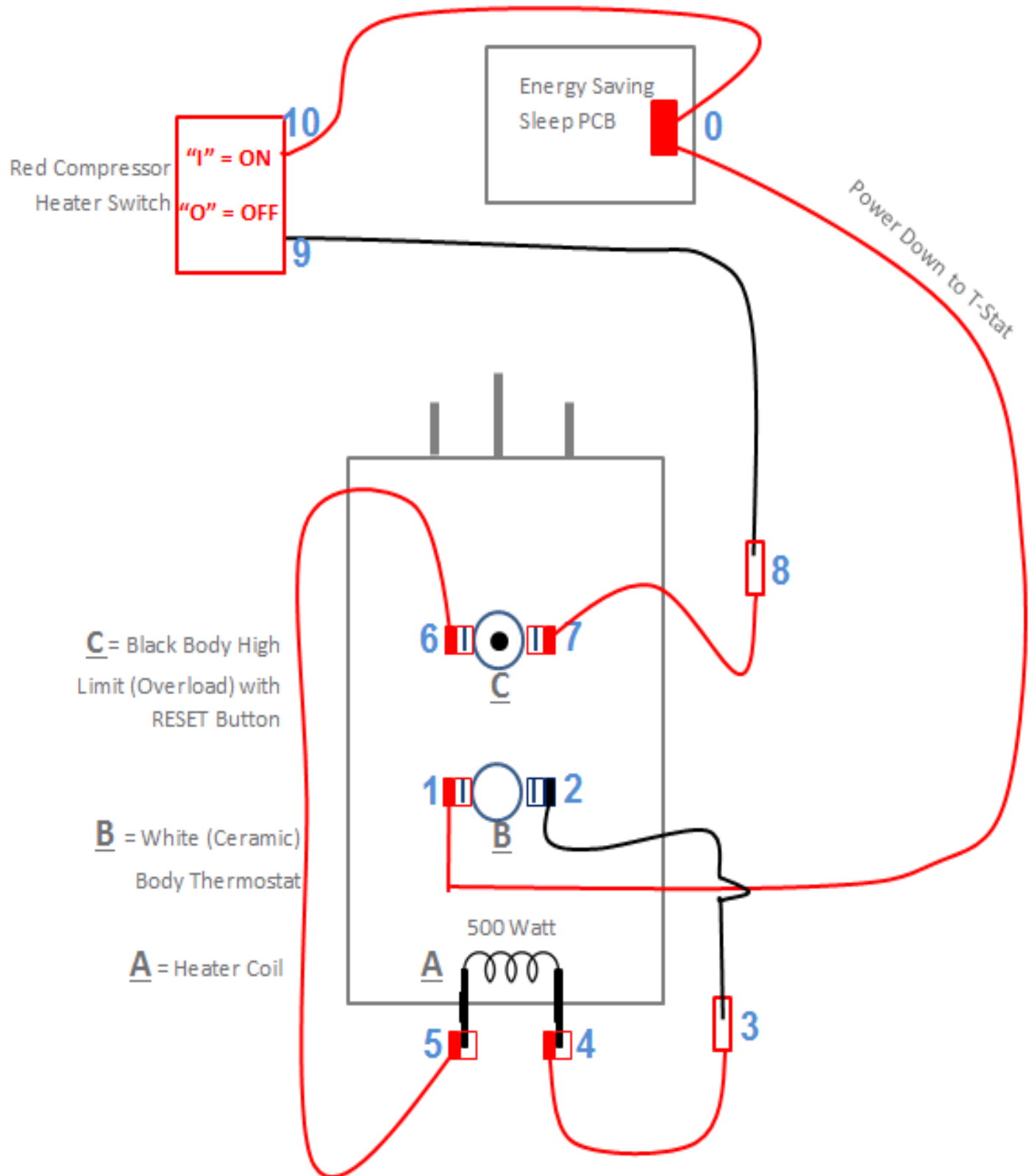

Descaling through the inlet and/or outlet lines only will not clean the vent chamber and outlet vent hole properly.

HEATER CIRCUIT

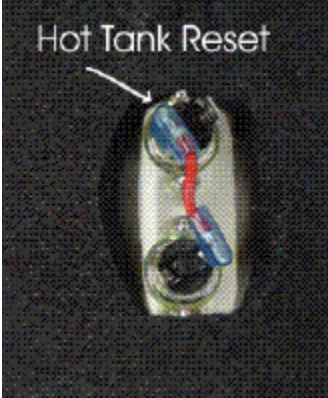

RESETTING THE HOT TANK OVERLOAD OR HIGH LIMIT SAFETY

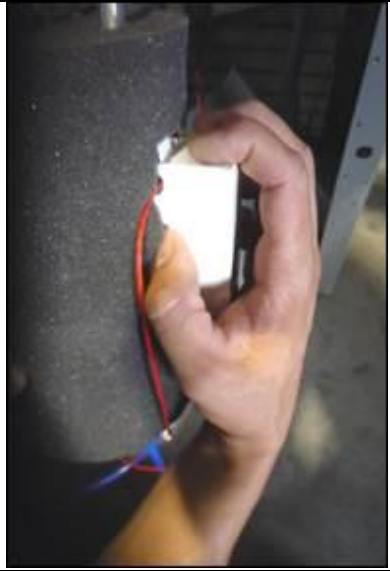
1.	Red Compressor/Heater Switch must be in the <i>O=OFF</i> position	
2.	Unplug the Power Cord from rear of unit.	
3.	Remove the Lower Front Panel of unit by removing the Phillips head screws underneath the Lower Front Panel.	
4.	Locate the Protective Metal Box on the rear of the Hot Tank. As you look through the condenser coils on the rear of the unit, you will see the Hot Tank located on the right-hand side.	
5.	<p>From the Front of the Water Treatment System, reach up behind the Hot Tank and take hold of the protective metal box covering the thermostat and overload on the Hot Tank.</p> <p>There are nuts that secure the Protective Metal Box to the Hot Tank, are loose enough to allow you to remove the Protective Metal Box.</p> <p>If the nuts on the metal box are too tight, loosen the nuts securing the Hot Tank to the Upper Base of the WL100 Water Treatment System unit and lower the Hot Tank so you can remove the Protective Metal Box.</p>	

<p>6.</p>	<p><i>For demonstrative purposes, photos below have lowered the Hot Tank from the unit.</i></p> <p>Press the reset button</p>	 
<p>7.</p>	<p>Reattach the Protective Metal Box by depressing the top flap of the Protective Metal Box so it snaps back into its original position on the Hot Tank.</p>	
<p>8.</p>	<p>Replace the Lower Front Panel.</p>	
<p>9.</p>	<p>Plug in the Power Cord.</p>	
<p>10.</p>	<p>Turn on the Red Compressor/Heater Switch <i>I=ON</i> position</p> <p>The Hot and Cold Tanks must be filled with water BEFORE turning on the Red Heater and Compressor Switch.</p>	
<p>11.</p>	<p>Verify the WL10 Water Treatment System is fully operational before installing it at the customers' site.</p>	

HOT TANK DESCALING INSTRUCTIONS

The hot tank requires removal of mineral deposits (descaling) on a regular basis depending upon local water conditions. Descaling should take place every 6 to 12 months to preserve long-term reliability when source water has high mineral content or high TDS. Descaling removes calcium deposits, or scale, that can build up inside a tank over time. Scale is non-toxic but left unattended will hinder your unit's performance and result in a drip to the faucet as water expands in the hot tank while heating. Excess scale results in higher energy consumption and may cause premature failure of the hot tank. It is critical to descale the entire hot tank including the expansion or vent chamber to ensure proper operation. A random drip of hot water out the faucet is key indication the expansion chamber is not functioning properly, and descaling may be needed.

Use non-toxic cleaner such as ScaleKleen, DEZCAL, 20% Citric Acid Solution, or Vinegar Solution to remove mineral deposits as directed by the manufacturer.

⚠ WARNING! **PERSONAL PROTECTIVE EQUIPMENT REQUIRED.** *Always ensure proper ventilation and use rubber or nitrile gloves and eye protection when using chemicals. Refer to Material Safety Data Sheet for specific requirements of each product.*

⚠ CAUTION! **STAINLESS STEEL TANK DESCALING.**
The Hot Tank is made from stainless steel. Ensure descaling solution is compatible with stainless and always flush the unit completely. Dispose in an environmentally safe manner.

Materials Needed:

- Personal Protective Equipment. Rubber or Nitrile Safety Gloves and Protective Eyewear
 - Phillips Screwdriver, Temperature Gauge
 - Water Pitcher or Container to collect water dispensed from the faucet
 - 20 Liter (5 gallon) container or a drain basin
 - Citric Acid Based Descaler or Vinegar
 - ¼" Plastic Tubing, at least 4 feet in length, and assorted ¼" quick connect fittings
 - Inline Sanitizing Cartridge (Waterlogic Filter Sump without cartridge works well)
 - Food Coloring – FDA safe and biodegradable recommended.
1. Bypass Filters before starting the Descaling Procedure.
 2. Put descaler per directions and 3 drops of food coloring into the descaling cartridge.
 3. Connect Descaling Cartridge to the inlet water supply and connect to Inlet Bulkhead Fitting on the back of **WL100 Water Treatment System**. Turn on Water Supply.
 4. Select Hot Water and depress the Main Dispensing Button on the Front Control Panel until descaling solution (colored water) comes out of the Faucet. Container and drain basin will be required to catch water from the faucet.
 5. Turn off water supply and remove Sanitizing Cartridge from inlet water supply. Reconnect water supply to Inlet Fitting.

6. Allow descaling solution to remain in the Hot Tank for 15 minutes (length of time may vary depending on water conditions).
7. Place a pitcher, catch basin or other container under the faucet of the **WL100 Water Treatment System**.
8. Flush the Hot Tank until water runs clear.
9. Once clear Water dispenses from the Faucet, the Hot Tank has been descaled. Always ensure unit is performing to the customer's satisfaction.
10. Replace Filters.

⚠ WARNING! HOT WATER. *Unit produces Hot Water up to 87°C (189°F). Water above 52°C (125°F) can cause severe burns or scalding. Hot water should be dispensed carefully into insulated container to avoid injury.*

⚠ CAUTION! MUST REPLACE HOT TANK EVERY 3-5 YEARS DEPENDING ON USAGE. *The Hot Tank and its controls must be replaced a minimum of every 3-5 years depending on usage to ensure efficient and dependable operation.*

⚠ WARNING! REINSTALL ALL PANELS AND COVERS. *Always reinstall all Panels, Protective Covers, and Fasteners after servicing equipment. Failure to do so could result in severe personal injury and will void the certifications and warranty of the equipment.*

ADJUSTING COLD SET POINT

Cold Water Temperature – Factory Set Point is 41°F (5°C) and can be adjusted to 34°F - 54°F (1.1°C to 12.2°C)

The cold set point can be adjusted by accessing the cold thermostat adjustment screw under the decal at the rear of the unit.



Remove the red portion of the Cold Tank Temperature label to access the adjustment screw.

The factory set point is ~41°F and is indicated by the dot on sheet metal.



Turning the adjustment screw clockwise to lower the set point temperature.

Do not adjust past the “Max Cold” position at 3:00 position to avoid freezing the cold tank.



Turning the adjustment screw counter-clockwise to raise the set point temperature.

PROGRAMMING “DISABLING ENERGY SAVING SLEEP MODE”

All **WL100 Water Treatment Systems** come from the factory with Energy Saving Sleep Mode engaged to meet the Energy Star Certification requirements. Energy Star Sleep Mode disables the Heater Circuit if the hot dispense has not been used for 3 hours.

Selecting any button "wakes up" the **WL100 Water Treatment System** and turns the Heater circuit back on. The Hot Tank will typically take less than 10 minutes to heat the water from ambient to the 85°C (185°F) set point.

Unplug Power Cord and remove Top Cover to access Energy Saver PCB.

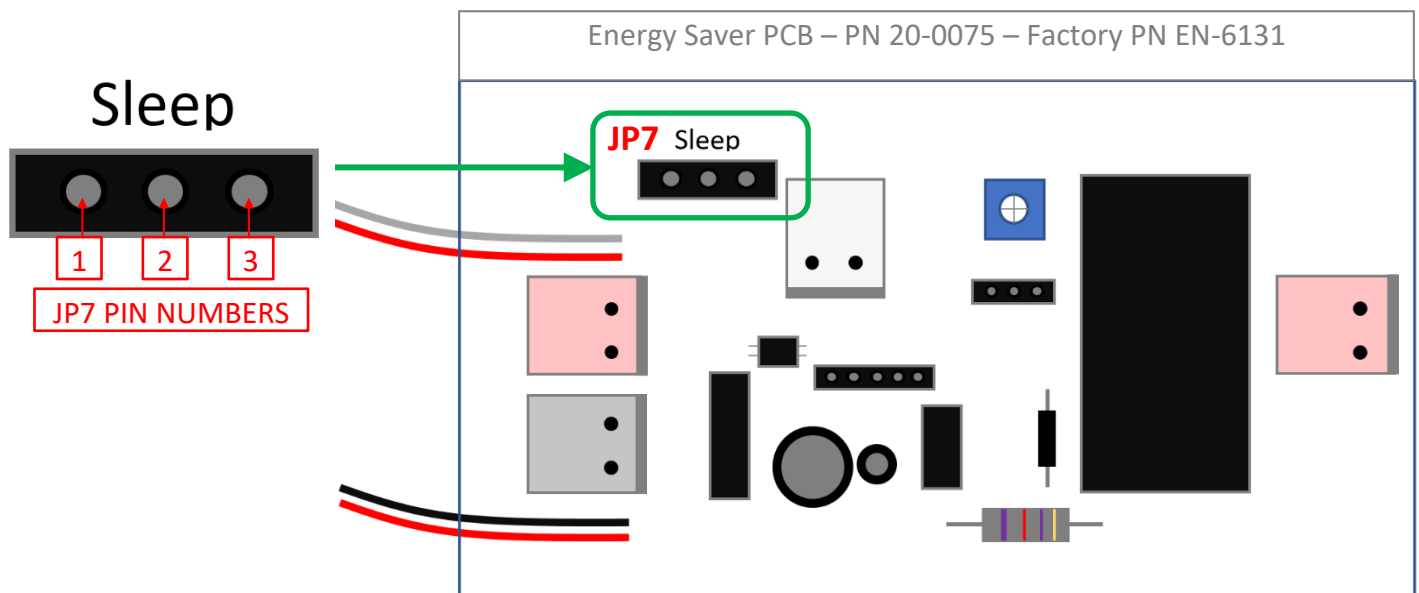

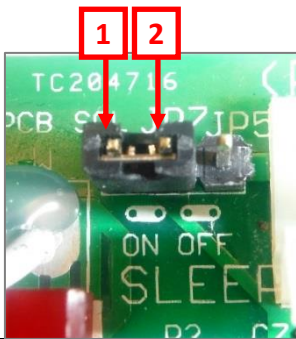
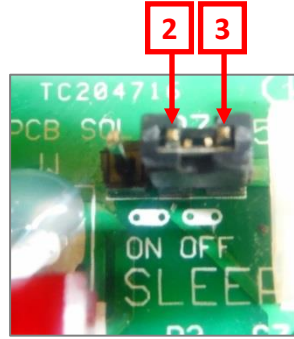
ENERGY SAVING SLEEP MODE	
ON	OFF
PCB Jumper JP7 (Pin Numbers 1 and 2) 	PCB Jumper JP7 (Pin Numbers 2 and 3) 

PROGRAMMING “CHANGING HOT WATER MODE TO AMBIENT WATER”

The **WL100 Water Treatment System** comes with set to Hot / Cold, which can be changed to Ambient / Cold settings. On the Energy Saver PCB, move the Jumper on JP9 from Pins 1 and 2 to Pins 2 and 3.

Unplug Power Cord and remove Top Cover to access Energy Saver PCB.

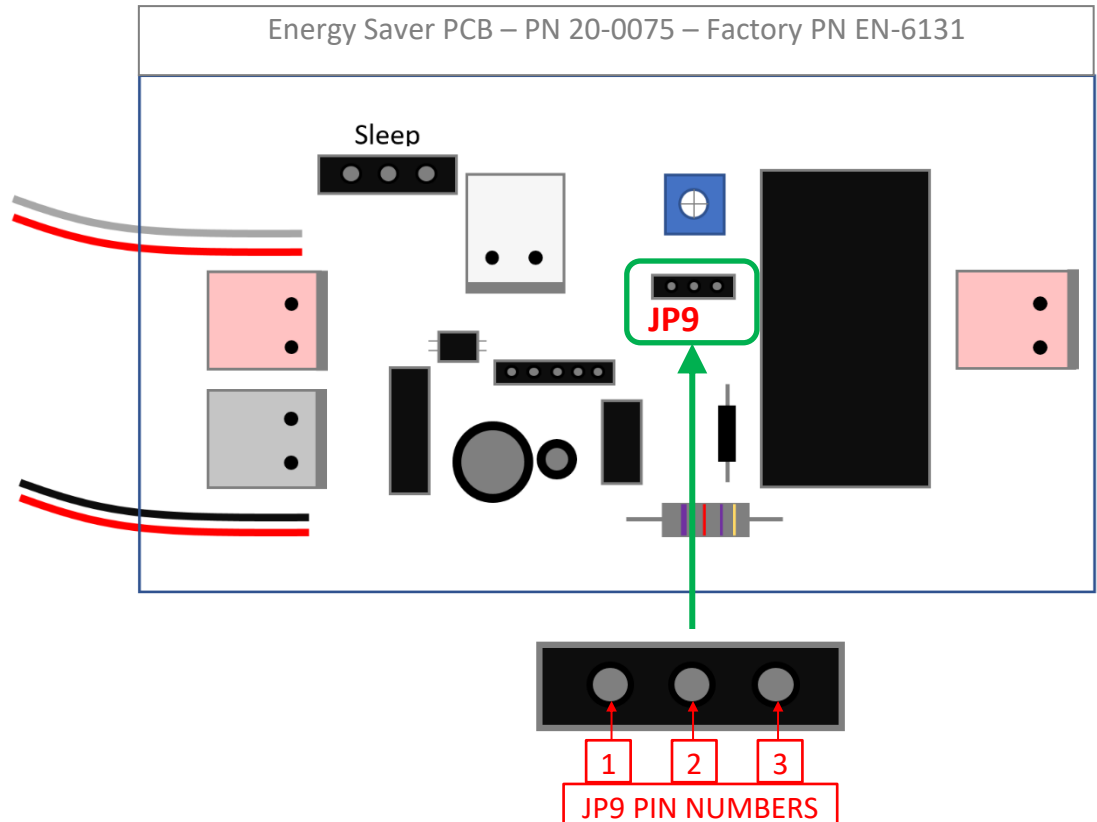

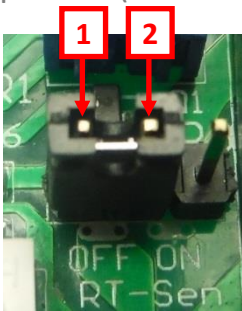
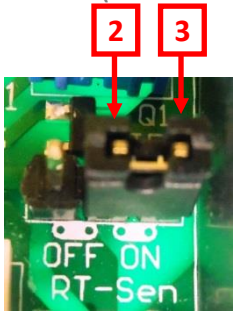
Hot and Cold (Factory Settings)	Ambient and Cold
PCB Jumper JP9 (Pin Numbers 1 and 2) 	PCB Jumper JP9 (Pin Numbers 2 and 3) 

REPLACEMENT COMPONENTS (CONSUMABLES)

Component	WLCP Part No.	Frequency of Replacement
Hot Tank Factory Setting - 85°C (185°F)	12-5615	Replace every 3 to 5 years depending on usage. Factory Part No HT-3041
GAC Filter - 10" Carbon Activated Inline Filter - <i>Optional</i>	FT-0035-IL-WTL	Every 6-months or as required. Filter Element PN FT-0038-WLT
Carbon Filter 1-micron 10" Inline CBC Filter Assembly <i>Optional</i>	FT-0034-IL-WLT	Every 6-months or as required. Filter Element PN FT-0036-WLT

Replacement parts can be obtained from *Waterlogic* or an *Authorized Waterlogic Dealer*. See *Parts Layouts, Drawings, and Lists* for additional repair parts.

Hot Tank Service

Hot Tanks (with controls) must be replaced at least every 3-5 years depending on usage. Descaling Hot Tank may be required on a regular basis depending upon filtration and local water conditions. See Hot Tank Descaling Instructions Section of this manual.

Surface Cleaning

Clean on a regular basis with damp lint free cloth. Never use harsh chemicals (alcohol or acid based) or abrasive agents on any part of the product to avoid damage. A mild cleaner such as Simple green or equivalent is recommended.

DISPOSAL

End of Life





At the **end of this product's life**, ensure that it is disposed of in an environmentally friendly manner which is fully compliant **with all Federal/State/Local Requirements and Guidelines**. Do not dispose of this appliance with normal household or business waste.

WL100 COUNTER TOP DRAWINGS AND PARTS LIST

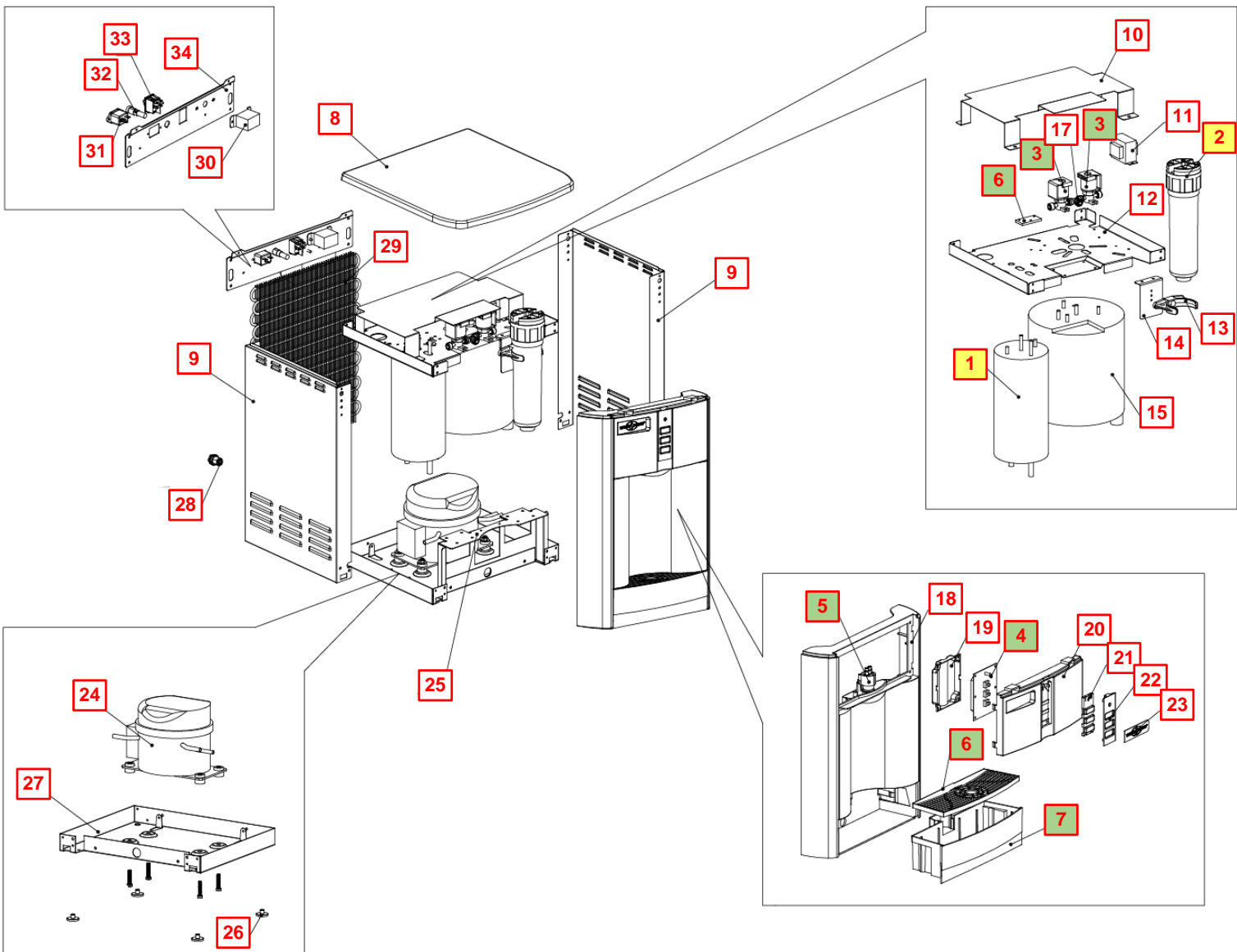
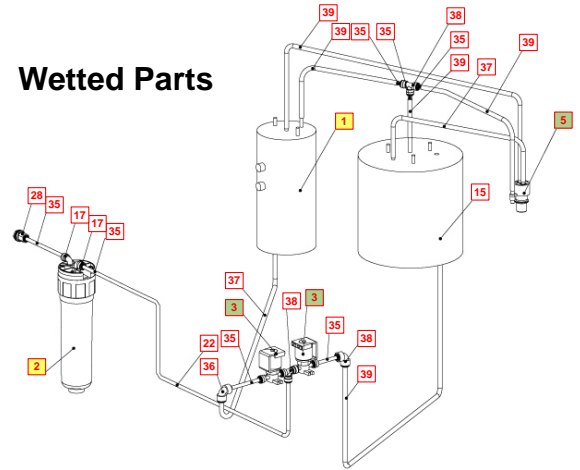
Yellow = Consumables
Green = Recommended spare parts

Wetted Parts



No	WLCP Part No.	Description	Part No	Stocked?	
Consumables					
1	12-5615	Hot Tank 1.6 Liter 100V / 500W Factory Set Point 85°C (185°F)	HT-3041	Yes	
2	FT-0035	GAC Filter - 10" Carbon Activated Inline Filter Optional Filter Element PN FT-0038	FT-0035-IL-WLT	Yes	
Recommended Spare Parts					
1.1	12-6900	Thermostat and Overload Metal Cover <i>Recommend stocking 2 each for every 10 units purchased</i>	ST-8290	Yes	
1.2	EL-0159	Overload with Manual Reset - 97°C (207°F) <i>Recommend stocking 2 each for every 10 units purchased</i>	EL-0159-L00-00	Yes	
1.3	12-1303	Hot Tank Thermostat - 85°C (185°F) <i>Recommend stocking 2 each for every 10 units purchased</i>	HT-3013A	Yes	
3	12-5665	Solenoid Valve with Terminal at Outlet Position <i>Recommend stocking 5 each for every 10 units purchased</i>	PU-4164-L00-00	Yes	
3.1	CU-0001	Solenoid Cushion <i>Recommend stocking 5 each for every 10 units purchased</i>	CU-0001	Yes	
4	20-0040	Display PCB <i>Recommend stocking 2 each for every 10 units purchased</i>	EN-6130	Yes	
5	10-2700	Faucet Assembly <i>Recommend stocking 2 each for every 10 units purchased</i>	PL-1011	Yes	
5.1	10-2600	Natural Faucet O-Ring – Silicon White <i>Recommend stocking 2 each for every 10 units purchased</i>	CT-2007	Yes	

5.2	10-3048	Faucet Nipple – Blue with Screen <i>Recommend stocking 2 each for every 10 units purchased</i>	PL-1013	Yes	
6	20-1040	Drip Tray Grill Charcoal <i>Recommend stocking 5 each for every 10 units purchased</i>	PL-1362-L00-CL	Yes	
	20-0065	Drip Tray Grill – Blue <i>Recommend stocking 5 each for every 10 units purchased</i>	PL-1362	Yes	
7	20-1035	Drip Tray Body – Charcoal No Logo <i>Recommend stocking 5 each for every 10 units purchased</i>	PL-1361-L00-CL	Yes	
	20-0070	Drip Tray Body – Blue No Logo <i>Recommend stocking 5 each for every 10 units purchased</i>	PL-1361	Yes	
Remainder of Parts					
8	20-1045	Top Cover Flat - Charcoal Textured	PL-1366-L00-CL	Yes	
	20-0005	Top Cover Flat – Blue	PL-1366	Yes	
9	12-5675	Side Panel – Counter Top only	ST-8148-A	Yes	
10	12-6900	High Voltage Cover Counter Top Only	ST-8301	Yes	
11	12-1200	Power Transformer 120V / 60Hz	EL-5021	Yes	
12	12-3165	Upper Shelf Counter Top Only	ST-8150-B	Yes	
13	20-1010	2.8” Filter Clip for In-Line Filter	PU-4161	Q	

14	20-1015	Filter Bracket Counter Top Only	ST-8326	Yes	
15	NA	2 Liter Cold Tank Countertop Only	CT-2087-A	Special Order	
16	20-0075	Energy Saver PCB	EN-6131	Yes	
16.1	20-1005	Jumper Pin	EN-6082	Yes	
17	NA	1/4" Union Elbow John Guest P/N P10308S	PU-4008	Purchase from John Guest	
18	20-0030	Front Upper Drip Tray Insert Panel - when purchasing, also request Hot Water Caution Label LP-7169 / 12-0001 to adhere to front of this Panel.	PL-1365	Yes	
18.1	12-0001	Hot Water Caution Label – Adhere to Front Upper Drip Tray Insert Panel.	LP-7169	Yes	
19	20-0035	Front PCB Cover	PL-1369	Yes	
20	20-1050	Front Upper Insert Panel - Charcoal	PL-1367-L00-CL-BIO	Yes	
	20-0045	Front upper Insert Panel – Blue	PL-1367	Yes	
21	20-0050	Silicon Button Keypad	PL-1370	Yes	
22	20-0055	Button PCB Insert Panel - Silver	PL-1368	Yes	
23	20-1030	WL100 Label – Front Upper Insert Panel - Charcoal	LP-0269-L00-00	Yes	

	20-0060	WL100 Label – Front Upper Insert Panel – Blue	LP-7292	Yes	
24	NA	Compressor 120V / 60Hz	CO-9045	Special Order	
24.1	12-1001	Filter Dryer	CO-9008	Yes	
24.2	10-3003	Compressor Starter Relay	CO-9016	Yes	
24.3	10-5018	Compressor Overload	CO-9015	Yes	
25	12-3175	Filter Bracket Counter Top Only	ST-8152-B	Yes	
26	12-3150	Unit Rubber Feet – Counter Top Only	PL-1251-CN	Yes	
27	12-3170	Bottom Panel Counter Top Only	ST-8151-A	Yes	
28	10-3067	Bulkhead Union ¼" x ¼" John Guest P/N PI1208S	PU-4028	Yes	
29	12-3100	Wire Condenser Counter Top Only	CO-9031	Special Order	
30	19-1069	Cold Tank Thermostat	CT-2070-A	Yes	
30.1	LP-0326	Cold Adjustment Cover Label	LP-0326-L00-00	Yes	
31	19-1090	Socket for Plug Connection	EL-0061-L00-00	Yes	
31.1	19-1015	Gasket for Power Socket	ST-8052	Yes	

32	10-3014	Fuse Holder and Fuse 120V / 15A with One Wire	EL-5053	Yes	
32.1	10-3013	Fuse 120V / 15A	EL-5010	Yes	
33	12-5600	Red Heater and Compressor Switch	EL-5019-A	Yes	
34	12-5674	Back Panel – Silver Countertop Only	ST-8253	No	
35	NA	JG LLD PE Tube - Blue O.D.1/4" John Guest P/N PE-08-BI-1000F-B	PU-4031	Purchase from John Guest	
36	NA	5/16" X 1/4" Reducing Elbow John Guest P/N PI211008S	PU-4007	Purchase from John Guest	
37	10-3062	JG LLDPE Tube - Blue 8mm John Guest P/N PE-0806-100M-B	PU-4014-A	Yes	
36	NA	1/4" Union Tee John Guest P/N P10208S	PU-4011-A	Purchase from John Guest	
39	10-7040	Silicon Tube 5/16" for Hot Water	PU-4064	Yes	
Not Shown	10-3007	Power Cord – 120V / 60Hz	EL-5001-B	Yes	









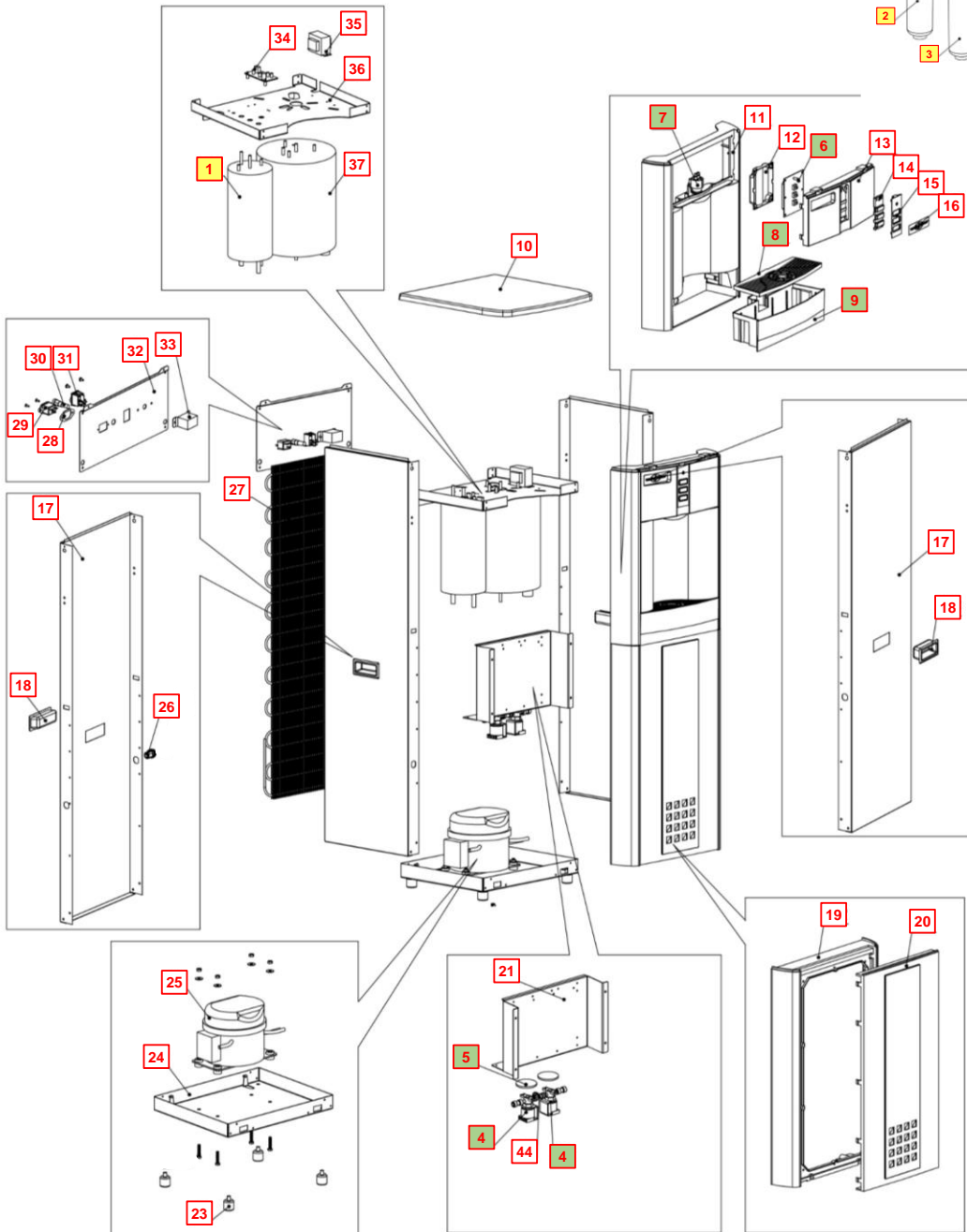
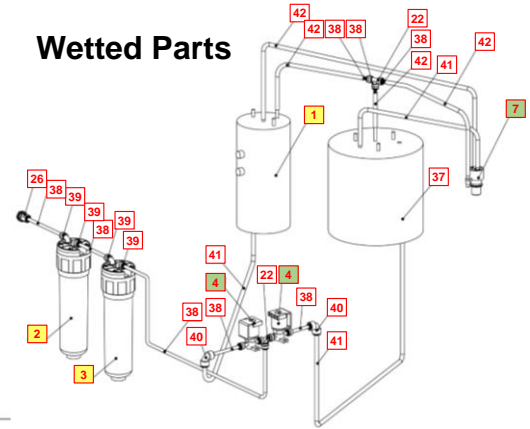

WL100 TOWER DRAWING AND PARTS LIST

Yellow = Consumables

Green = Recommended spare parts

Wetted Parts



No	WLCP Part No.	Description	Part No	Stocked?	
Consumables					
1	12-5615	Hot Tank 1.6 Liter 100V / 500W Factory Set Point 85°C (185°F)	HT-3041	Yes	
2	FT-0035	GAC Filter - 10" Carbon Activated Inline Filter Optional Filter Element PN FT-0038	FT-0035-IL-WLT	Yes	
3	FT-0034	Sediment Filter – 1 Micron CBC Cyst Reduction Inline Filter - Optional Filter Element FT-0036	FT-0034-IL-WLT	Yes	
Recommended Spare Parts					
1.1	12-6900	Thermostat and Overload Metal Cover <i>Recommend stocking 2 each for every 10 units purchased</i>	ST-8290	Yes	
1.2	EL-0159	Overload with Manual Reset - 97°C (207°F) <i>Recommend stocking 2 each for every 10 units purchased</i>	EL-0159-L00-00	Yes	
1.3	12-1303	Hot Tank Thermostat - 85°C (185°F) <i>Recommend stocking 2 each for every 10 units purchased</i>	HT-3013A	Yes	
4	12-5665	Solenoid Valve with Terminal at Outlet Position <i>Recommend stocking 5 each for every 10 units purchased</i>	PU-4164-L00-00	Yes	
5	CU-0001	Solenoid Cushion <i>Recommend stocking 5 each for every 10 units purchased</i>	CU-0001	Yes	
6	20-0040	Display PCB <i>Recommend stocking 2 each for every 10 units purchased</i>	EN-6130	Yes	
7	10-2700	Faucet Assembly <i>Recommend stocking 2 each for every 10 units purchased</i>	PL-1011	Yes	

7.1	10-2600	Natural Faucet O-Ring – Silicon White <i>Recommend stocking 2 each for every 10 units purchased</i>	CT-2007	Yes	
7.2	10-3048	Faucet Nipple – Blue with Screen <i>Recommend stocking 2 each for every 10 units purchased</i>	PL-1013	Yes	
8	20-1040	Drip Tray Grill Charcoal <i>Recommend stocking 5 each for every 10 units purchased</i>	PL-1362-L00-00	Yes	
	20-0065	Drip Tray Grill – Blue <i>Recommend stocking 5 each for every 10 units purchased</i>	PL-1362	Yes	
9	20-1035	Drip Tray Body – No Logo <i>Recommend stocking 5 each for every 10 units purchased</i>	PL-1361-L00-CL	Yes	
	20-0070	Drip Tray Body – Blue No Logo <i>Recommend stocking 5 each for every 10 units purchased</i>	PL-1361	Yes	
Remainder of Parts					
10	20-1045	Top Cover Flat - Charcoal Textured	PL-1366-L00-CL	Yes	
	20-0005	Top Cover Flat – Blue	PL-1366	Yes	
11	20-0030	Front Upper Drip Tray Insert Panel - - <i>when purchasing, also request Hot Water Caution Label LP-7169 / 12-0001 to adhere to front of this Panel.</i>	PL-1365	Yes	
11.1	12-0001	Hot Water Caution Label – Adhere to Front Upper Drip Tray Insert Panel.	LP-7169	Yes	
12	20-0035	Front PCB Cover	PL-1369	Yes	
13	20-1050	Front Upper Insert Panel - Charcoal	PL-1367-L00-CL-BIO	Yes	
	20-0045	Front upper Insert Panel – Blue	PL-1367	Yes	

14	20-0050	Silicon Button Key mat	PL-1370	Yes	
15	20-0055	Button PCB Insert Panel - Silver	PL-1368	Yes	
16	20-1030	WL100 Label – Front Upper Insert Panel - Charcoal	LP-0269-L00-00	Yes	
	20-0060	WL100 Label – Front Upper Insert Panel - Blue	LP-7292-A	Yes	
17	20-0010	Side Panel - Tower Only	ST-8249-A	Yes	
18	12-8058	Side Panel Plastic Handle - Tower Only	PL-1123	Yes	
19	20-0025	Front Lower Panel Tower Only	PL-1364	Yes	
20	20-1055	Front Lower Insert Panel - Charcoal Tower Only	PL-1363-L00-CL	Yes	
	20-0020	Front Lower Insert Panel - Blue Tower Only	PL-1363	Yes	
21	20-0015	Filter Fixing Bracket - Tower Only	ST-8138-B	Yes	
22	NA	¼" Equal Tee Connector John Guest P/N P10208S	PU-4011	Purchase from John Guest	
23	10-3083	Unit Control Rubber Feet - Tower Only	ST-8167-CN	Yes	
24	20-0015	Bottom Tray- Tower Only	ST-8137-A	Yes	

25	NA	Compressor 120V / 60Hz	CO-9045	Special Order	
25.1	12-1001	Filter Dryer	CO-9008	Yes	
25.2	10-3003	Compressor Starter Relay	CO-9016	Yes	
25.3	10-5018	Compressor Overload	CO-9015	Yes	
26	10-3067	Bulkhead Union 1/4" x 1/4" John Guest P/N PI1208S	PU-4028-A	Yes	
27	12-8102	Wire Condenser - Tower Only	CO-9027	Special Order	
28	19-1015	Gasket for Power Socket	ST-8052	Yes	
29	TBD	Socket for Plug Connection	EL-0061-L00-00	Yes	
30	10-3014	Fuse Holder and Fuse 120V / 15A with One Wire	EL-5053	Yes	
30.1	10-3013	Fuse 120V / 15A	EL-5010	Yes	
31	12-5600	Red Heater and Compressor Switch	EL-5019-A	Yes	
32	12-5673	Back Panel Tower Only	ST-8135-A	No	
33	19-1069	Cold Tank Thermostat	CT-2070-A	Yes	
33.1	LP-0326	Cold Adjustment Cover Label	LP-0326-L00-00	Yes	
34	20-0075	Energy Saver PCB	EN-6131	Yes	
34.1	20-1005	Jumper Pin	EN-6082	Yes	

34.2	10-3017	Plastic PCB Support	EN-6059	Yes	
35	12-1200	Power Transformer 120V / 60Hz	EL-5021	Yes	
36	12-8003	Upper Shelf - Tower Only	ST-8136-A	Yes	
37	NA	2 Liter (0.5 Gallon) Cold Tank Tower Only	CT-2087	Special Order	
38	NA	JG LLD PE Tube - Blue O.D.1/4" John Guest P/N PE-08-BI-1000F-B	PU-4031	Purchase from John Guest	
39	NA	1/4" Equal Elbow Connector John Guest P/N P10308S	PU-4008	Purchase from John Guest	
40	Purchase from John Guest	5/16" X 1/4" Reducing Elbow John Guest P/N P1211008S	PU-4007-A	No	
41	10-3062	JG LLDPE Tube - Blue 8mm (PE-0806- 100M-B)	PU-4014	Yes	
42	10-7040	Silicon Tube 5/16" for Hot Water	PU-4064-L00- 00	Yes	
Not shown	10-3099	2 1/2" Filter Clip - Tower Only	PU-4024	Yes	
Not shown	10-3098	2" Filter Clip for In-Line Filter	PU-4025	Yes	
Not Shown	10-3007	Power Cord – 120V	EL-5001-B	Yes	

WL100 WATER FLOW DIAGRAM

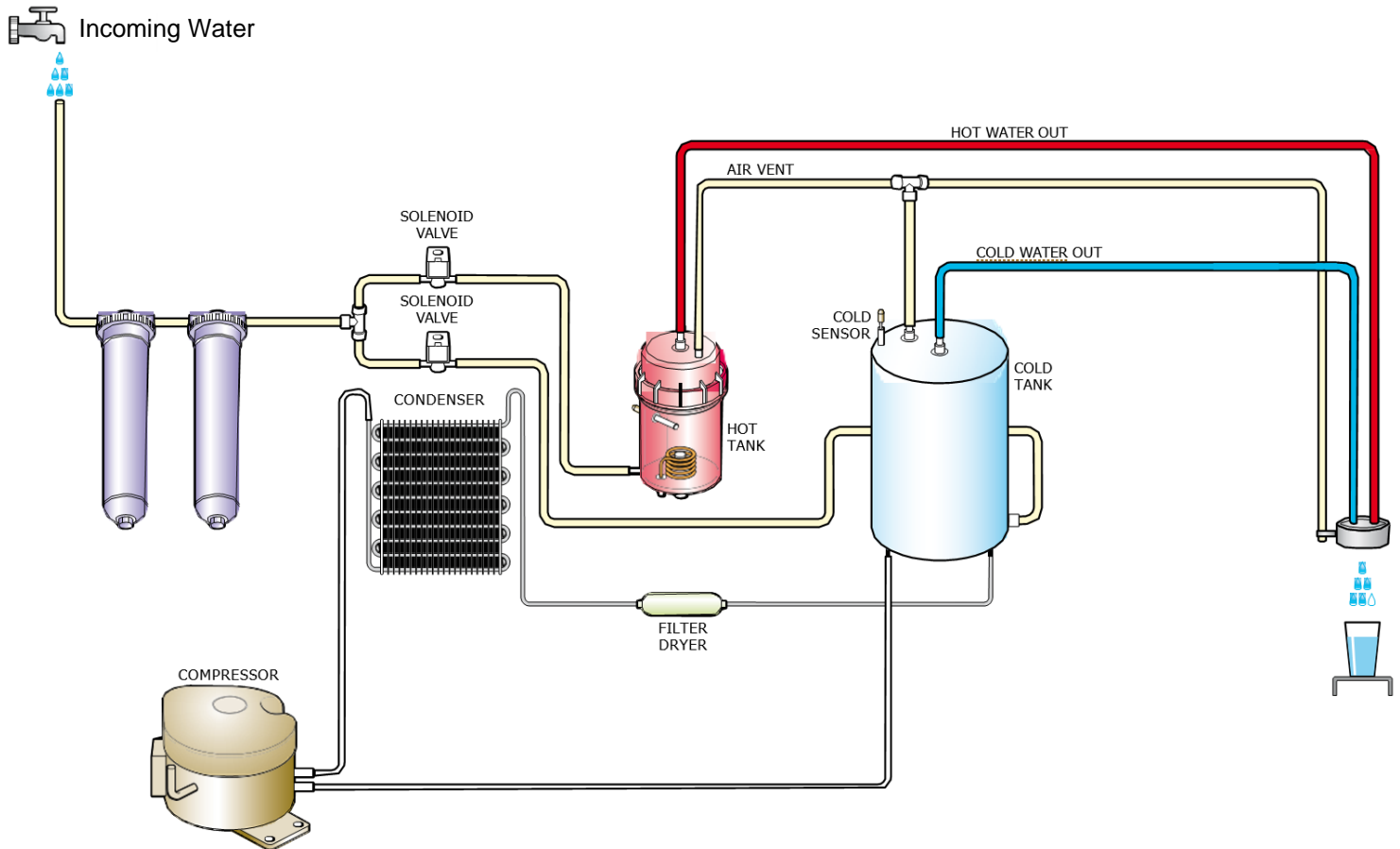

WL100 ELECTRICAL DIAGRAM

⚠ DANGER! HIGH VOLTAGE ELECTRICAL HAZARD. PCB (Printed Circuit Board) contains High Voltage. Only trained and qualified technicians should attempt live testing.

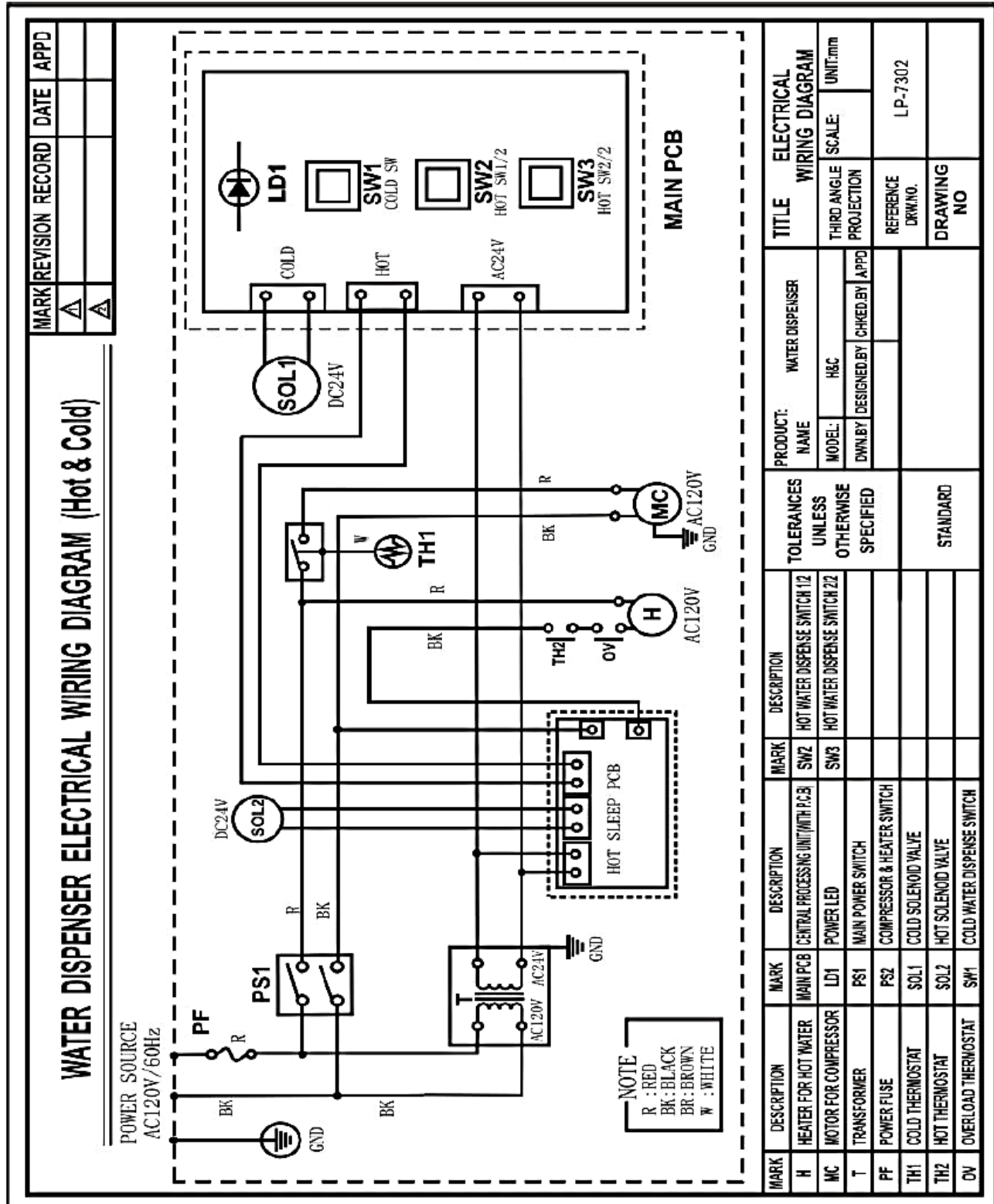

PRE-INSTALLATION PROCEDURES

⚠ DANGER! ELECTRICAL SHOCK HAZARD.

Only qualified personnel who have read and understand this entire manual should attempt to install, or service this unit, failure to do so could result in death or serious injury. DO NOT plug into an electrical supply until specifically instructed.

Red Compressor/Heater Switch must be in the O=OFF position while the Hot Tank is empty. Damage could occur within one minute and the two Hot Tank Overload Devices (High Safety Limit) require manual reset if heater is turned on with an empty Hot Tank.



⚠ WARNING! ALWAYS SANITIZE BEFORE USE.

Sanitize before use to eliminate any potential microbiological contaminants.

⚠ CAUTION! DRIP TRAY DRAIN.

If you intend to provide a drip tray drain for your customer, be aware that you will be called multiple times per month to service and unclog the tubing leading away from the drip tray to drain. Users will clog the drain with paper clips, erasers, napkins, tea bags, gum, and various other unintended items. Waterlogic recommends you establish a minimum of weekly visits to the machine for cleaning of the drip tray drain.

Materials Needed:

- Personal Protective Equipment. Rubber or Nitrile Safety Gloves and Protective Eyewear
- Phillips Screwdriver
- Temperature Gauge
- Water Pitcher or Container to collect water from the faucet
- 19 Liter (5 gallon) container or drain basin
- Sanitizer - Household Bleach (5.25% Sodium Hypochlorite) or Citric Acid Based Cleaner
- ¼" Plastic Tubing, at least 1.25 meters (4 feet) in length, and assorted ¼" quick connect fittings
- TDS Meter and Test Strips for measuring chlorine – Optional
- Sanitizing Cartridge – an empty Waterlogic Filter with the cartridge removed

1. Unpack the **Waterlogic WL100 Water Treatment System** and check exterior for damage.

Sanitizing

Sanitize using a Household Bleach (5.25% Sodium Hypochlorite solution) or another approved cleaner throughout the cold-water circuit. Follow all instructions on the sanitizer and flush with fresh water through the faucet until odor and taste is acceptable.

⚠ WARNING! USE PROPER PERSONAL PROTECTIVE EQUIPMENT

Always ensure proper ventilation and use proper personal protective equipment such as gloves and eye protection when using chemicals. Refer to Material Safety Data Sheet for specific requirements of each chemical product. Take all necessary precautions to prevent sanitizer from contacting eyes, clothing, and any other surfaces in could damage (carpets).

- Put 5 Millimeter (1 Teaspoon) of sanitizer per directions or use Bleach Solution (5 Millimeter = 1 Teaspoon = 1/6 ounces = ½ cap full) of household bleach (Sodium Hypochlorite 5 - 10% Concentration) in the Sanitizing Cartridge. Always ensure sanitizer is compatible with stainless steel and acetyl plastic.
- Connect Sanitizing Cartridge to inlet water supply and connect to Inlet Bulkhead Fitting on back of unit. Turn on water supply.
- Connect power to the **WL100 Water Treatment System**. DO NOT TURN ON RED HEATER – COMPRESSOR SWITCH AT THIS TIME. *Red Compressor/Heater Switch must be in the O=OFF position.*



Fill the Cold Circuit with Sanitizer

- Depress the Main Dispensing Button on the Front Control Panel until cold water/sanitizing solution comes out the faucet. **NOTE:** Container and drain basin will be required to catch the water from the faucet.

⚠ WARNING! *Use Personal Protective Equipment. Gloves and Eye Protection Required. The first 8 or 11 Liters (2 or 3 gallons) of water will contain concentrated sanitizer. Use extreme care!*

- Turn off water supply and remove Sanitizing Cartridge from inlet water supply. Reconnect water supply to Inlet Bulkhead Fitting.

Flush Filters

⚠ CAUTION! **FILTER FLUSH REQUIRED.**

WL100 Water Treatment Systems are not supplied with filters. Filters should be configured to optimize your system. Filters need to be configured and specified to do the job given the local water conditions, usage, maintenance schedule, and placement restrictions.

In order for our filters to perform as represented and to provide the best quality water possible, it is essential that filters be replaced periodically. The frequency of filter changes depends upon your water quality and your water usage. For example, if there is a lot of sediment and/or particles in your water, then you will have to change your filters more frequently than a location with little to no sediment. Be sure to replace your filters whenever you notice a decline in the performance, whether it is a drop in flow rate and/or pressure or an unusual taste in the water.

- Flush thoroughly per filter manufacturers' recommendation with fresh water to drain.

8. Once flushed, install the filters. Following the flow direction on the filter.

NOTE: Filters should not be flushed prior to 24 hours before installation to limit Microbial Growth.

9. Connect **WL100 Water Treatment System** to power.

⚠ CAUTION! **NEVER TURN ON HEATER BEFORE FILLING HOT TANK.**

Red Compressor/Heater Switch must be in the O=OFF position while the Hot Tank is empty. Damage could occur within one minute and the overload (high limit) will require manual reset if Heater is turned on with an empty Hot Tank.



Flushing the Sanitizer from the Machine

10. Place a pitcher, catch basin, or other container under the faucet of the **WL100 Water Treatment System**.
11. Flush the Cold Tank. Run several gallons of water through the faucet by dispensing cold water to dilute and remove the sanitizer from the cold circuit. Chlorine test strips can be used to evaluate the water.
12. Once the sanitizer odor/taste has been flushed out of the cold side of the machine the sanitization process for the Cold Circuit is now complete.

Fill the Hot Tank

13. Press the Hot Water Select Button, followed by the Main Dispensing Button to fill the Hot Tank. Water will dispense from the faucet once the Hot Tank is full. Flush until water is clear.

⚠ WARNING! **HOT CIRCUIT IS NOT SANITIZED.**

Water in the Hot Circuit is not sanitary until the temperature exceeds 77°C (171°F) for at least 5 minutes.

Compressor Test

14. Switch Red Compressor / Heater to on **I=ON position**. Always ensure Tanks are full of water before turning on the Heater or the Overload (High Limit) opens and require manual reset. If the Wire Condenser at back of the **WL100 Water Treatment System** is warm, the refrigeration system is working.



15. Once the machine reaches its target temperature, the Compressor will shut off. Draw a glass of cold water and verify it has chilled to proper temperature.

Heater Test

16. Always ensure tanks are full of water before turning on the Heater or the overload (high limit) will open and require manual reset. It will take the Heater approximately 10 minutes to heat the water from ambient 24°C (75°F) to the factory set point of 85°C (185° F). Dispense a cup of hot water to ensure the temperature/odor/taste is acceptable.

⚠️ WARNING! HOT WATER. *Unit produces Hot Water up to 87°C (189°F). Water above 52°C (125°F) can cause severe burns or scalding. Hot water should be dispensed carefully into insulated container to avoid injury.*

WL100 COUNTER TOP DRAINING INSTRUCTIONS

Draining Notes

Drain the **WL100 Water Treatment System** for transportation.

⚠ WARNING! **STORE UNIT EMPTY. ALWAYS SANITIZE BEFORE REUSE.**
The unit must be completely drained and sealed before storing to avoid stagnation and reduce microbial growth).

Prior to draining the Hot Tank, turn off the Red Heater and Compressor Switch – **O=OFF**, and dispense 2 Liters (½ Gallon) of hot water from the **WL100 Water Treatment System**. As hot water is dispensed from the Faucet of the unit, colder water will be introduced into the Hot Tank. Since the Red Heater and Compressor Switch is turned off, the Heater will not energize and heat the incoming tap water. Following this precaution prevents exposing personnel and equipment (drains, catch basin, etc.) from scalding hot water.



Disable Cold and Hot Tanks

1. Turn off the Red Heater and Compressor Switch to disable the Heater and Compressor. *Red Compressor/Heater Switch must be in the O=OFF position*
2. Dispense 2 liters (½ Gallon) of water through the Hot Tank to cool the water temperature in the Hot Tank and avoid burns.



⚠ WARNING! **HOT WATER.** *Unit produces Hot Water up to 87°C (189°F). Water above 52°C (125°F) can cause severe burns or scalding. Hot water should be dispensed carefully into insulated container to avoid injury.*

Turn off Water Supply and Bleed Water Pressure

3. Isolate **WL100 Water Treatment System** from feed water by turning off the supply.
4. Dispense cold still water to relieve any pressure built up in the system.

Drain the Cold Water Tank and Circuit

5. Remove Top Cover.

- Remove Front Panel. Remove 2 Phillip screws securing Front Panel.

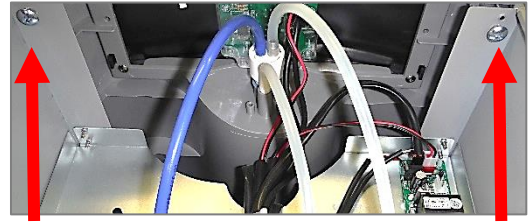

- Unseat Faucet Assembly from Front Panel.



- Unclip the White, Red and Black wire connectors from PCB to allow Front Cover to be removed.

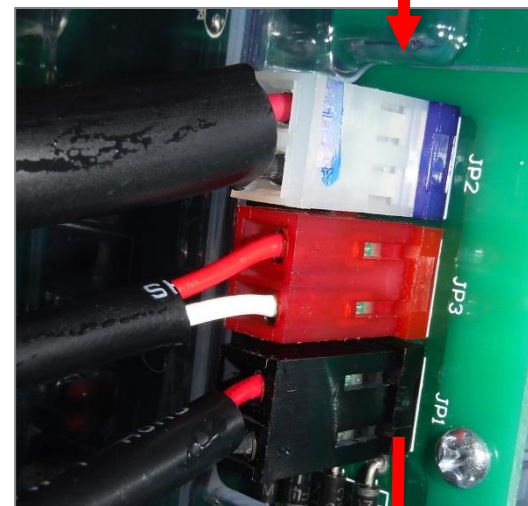

- Remove Front Panel

- Disconnect tubing to allow water to drain from the **WL100 Water Treatment System**.

Catch water in a pitcher, catch basin or another container.

- Dry inside of the **WL100 Water Treatment System**.

- Replace Front Panel.



WL100 TOWER DRAINING INSTRUCTIONS

Draining Notes

Drain the **WL100 Water Treatment System** for transportation.

⚠ WARNING! STORE UNIT EMPTY. ALWAYS SANITIZE BEFORE REUSE.

The unit must be completely drained and sealed before storing to avoid stagnation and reduce microbial growth).

Prior to draining the Hot Tank, turn off the Red Heater and Compressor Switch (*O = OFF*) and dispense 2 liters (½ Gallon) of hot water from the **WL100 Water Treatment System**. As hot water is dispensed from the faucet of the unit, colder water will be introduced into the Hot Tank. Since the Red Heater and Compressor switch is turned off, the Heater will not energize and heat the incoming tap water. Following this precaution prevents exposing personnel and equipment (drains, catch basin, etc.) to scalding hot water.



Red Compressor/Heater Switch must be in the O=OFF position.

Disable Cold and Hot Tanks

1. Ensure the Red Heater and Compressor Switch is off (*O = OFF*) to disable the Heater and Compressor.
2. Dispense 2 liters (½ Gallon) of water through the Hot Tank to cool the water temperature in the Hot Tank and avoid burns.



⚠ WARNING! HOT WATER. Unit produces Hot Water up to 87°C (189°F). Water above 52°C (125°F) can cause severe burns or scalding. Hot water should be dispensed carefully into insulated container to avoid injury.

4. Dispense cold still water to relieve any pressure built up in the system.

Drain the Cold Water Tank and Circuit

5. Remove the Lower Front Panel to access tank feed lines.

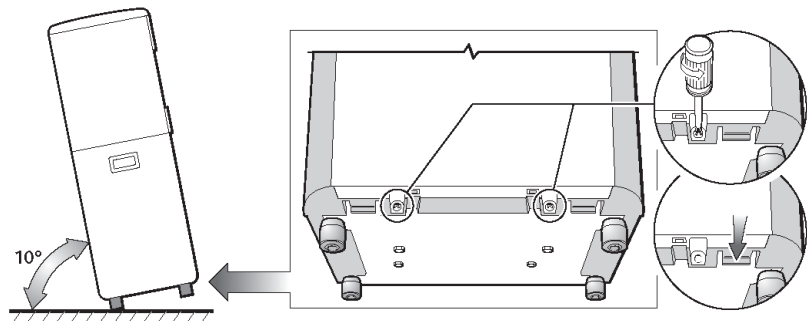

6. Remove the Hot and Cold water supply lines from the inlet line Solenoids.
7. Disconnect tank line outlet lines from Hot and Cold Solenoids to drain into basin or bucket.

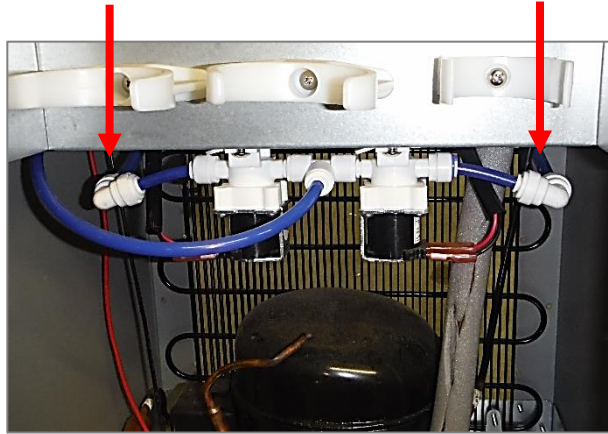

8. Turn outlet fittings outward to avoid water spilling onto the Compressor.



9. Reconnect Tubing into Outlet Elbows once drained.
10. Dry inside of Bottom Tray as necessary.
11. Replace Lower Front Panel

INSTALLATION PROCEDURES

Safety and Installation Guidelines

Ensure all Local, State, and Federal Laws and Codes including health and safety guidelines are met when installing **Waterlogic** Equipment. Only qualified service technicians should attempt installation and service of **Waterlogic** Equipment.

- ⚠ DANGER! ELECTRICAL SHOCK HAZARD.** *Always use a dedicated and properly grounded outlet. Unit should be protected by ground-fault circuit interrupter (GFCI) or residual current device (RCD) having a rated residual operating current not exceeding 30mA. Use only Waterlogic supplied power cord. Never use extension cords or power strips to connect unit. Do not use if the power supply cord is damaged. Always unplug from power supply prior to servicing.*
- ⚠ CAUTION! INDOOR USE ONLY.** *Never expose to direct sunlight, heat sources, or ambient air temperature above 37°C (100°F) or below 2°C (35°F). Install indoors and keep unit away from excessive humidity. Never expose to freezing temperatures. Ensure there is adequate clearance around the unit to allow refrigeration system condenser to dissipate heat. Warmer environments require more clearance around the unit. Minimum clearance around all surfaces of the machine is 2-inches. Installs where the ambient temperature exceeds 27°C (80°F), require a minimum of 4-inches clearance for proper heat dissipation and efficient operation.*
- ⚠ CAUTION! USE A WATER PRESSURE REGULATOR.** *Waterlogic will not be responsible for injury or damage caused by excessive water pressure. Operating pressure must be 40 psi to 60 psi. Be aware any of potential pressure surges caused by building/municipal pumping stations.*
- ⚠ CAUTION! USE UV STABILIZED SUPPLY LINES.** *Feed the unit with a potable ambient or cold water supply only. Feed water over 37°C (100°F) can damage the treatment components. Water block devices and external leak detectors are strongly recommended. Locate the unit as close to the water supply and the electrical connections as possible. Locate the unit as close to the water supply and the electrical connections as possible. Immediately isolate or close water supply valve and contact service representative if leak is noticed.*
- ⚠ WARNING! STORE AND TRANSPORT UNIT EMPTY. ALWAYS SANITIZE BEFORE USE.** *The unit must be completely drained and sealed before storing to avoid stagnation and reduce microbiological contamination (potential bacterial growth). Sanitize before use to eliminate any potential microbiological contaminants*

Pre-installation and sanitization procedures as prescribed in this manual must be performed before installing the **WL100 Water Treatment System**.

Always install indoors and place the **Waterlogic WL100 Water Treatment System** on a firm, flat and stable surface.

1. Attach the water supply line to the 1/4" feed water Inlet Bulkhead Fitting on the back of the unit. **Waterlogic** requires the use of a water pressure regulator. Water feed pressure must be between 40-60 psi. Turn on the water supply and check for leaks.

2. Check to ensure that the Red Heater and Compressor Switch is the *O=OFF* position.

NOTE: Switches have internal LED that illuminates when placed in *I=ON* position



3. Connect the power cord to the back of the **Waterlogic WL100 Water Treatment System** and to a 120 Volt supply.
4. Fill the Cold Tank. Hold a container under the Dispensing Faucet, press and hold Cold (Blue) Dispensing button until a continuous flow of water is obtained. Once a continuous flow is obtained, release the dispensing button. Cold Tank is now full.
5. Fill the Hot Tank. Hold a container under the dispensing faucet. Press both of the Hot (Red) Dispensing buttons until a continuous flow of water is obtained. Once a continuous flow is obtained, the Hot Tank is full.

⚠ CAUTION! NEVER TURN ON HEATER BEFORE FILLING HOT TANK.

Red Heater and Compressor Switch must be in the O=OFF position while the Hot Tank is empty. Damage could occur within one minute and the overload (high limit) will require manual reset if Heater is turned on with an empty Hot Tank.



6. Move the **Waterlogic WL100 Water Treatment System** into its final operating position. Be sure that a minimum of 5 cm (2 inch) clearance is maintained around both the sides and the back of the unit. This is important to allow proper airflow and heat exchange of refrigeration system.
7. Level unit using the adjustable feet to level if necessary. Never install on incline.

8. Turn the Red Heater and Compressor Switch on *I=ON* position.



9. When the unit has reached its Hot Temp Set Point, the Heater will cycle off. When the unit has reached its Cold Temp Set Point Temperature, the Compressor will cycle off.
10. Once the unit is at the target temperature(s), sample the water to ensure water meets expectations and additional rinsing or adjustment is not required.
11. Check the **WL100 Water Treatment System** for any leaks. External Leak Protection is always recommended.

POWER TROUBLESHOOTING INDEX

1. Red Heater and Compressor Power Switch won't light and the Red LED on the Front won't light
2. Red Power Switch is lit but the red LED on the Front is not lit
3. Compressor Runs but does Not Chill
4. Compressor is Not Running

1. Red Heater and Compressor Power Switch won't light and the Red LED on the Front won't light

Possible Reason	Solution
Circuit Breaker	Check the Circuit Breaker
Fuse is Blown	Replace Fuse
Defective / Loose Power Cord	Check that power cord is properly plugged in. If it is properly plugged in, use a different power cord to verify.
Failed Power Line Noise Filter, ElectroMagnetic Interference filter (EMI)	Replace EMI
Defective Red Heater / Compressor Switch	Replace Red Heater / Compressor Switch



2. Red Power Switch is lit but the Red LED on the Front is not lit

Possible Reason	Solution
Bad Transformer	Replace Transformer
Black Power Connector to the PCB is not properly connected	Properly connect.
Bad Front PCB	Replace Front PCB <i>Part Number EN-6130 – WLCP PN 20-0040</i>
Bad Energy Saver PCB	Replace Energy Saver PCB <i>Part Number EN-6131 – WLCP PN 20-0075</i>
Defective Red Heater / Compressor Switch	Replace Red Heater / Compressor Switch

3. Compressor Runs But Does Not Chill

Possible Reason	Solution
Condenser is dirty	Clean the condensing coil of any obstructions or dust.
Reduction of airflow into unit.	Make sure unit is not under minimum ventilation requirements (2 to 4 inches).
Compressor is running very hot.	Low or lost refrigerant. Refrigerant recharge required.

4. Compressor is Not Running

Possible Reason	Solution
Red Heater and Compressor Switch button on unit is in the off position	Turn Red Heater and Compressor Switch on. <i>I = ON</i> 
Compressor Starting Circuit	Turn Red Heater and Compressor Switch off. <i>O = OFF.</i> Remove the Compressor cap on side of the Compressor; Disconnect the black and red terminal connectors; Inspect the starter and overload relay for any defects. Replace components(s) as needed. Turn Red Heater and Compressor Switch on <i>I = ON</i> and retest Compressor operation.  

DISPENSING TROUBLESHOOTING INDEX

1. Irregular / Intermittent Dispensing from One Side
2. Dispensing won't stop when not holding the Dispensing Button
3. Steady Drip out of Faucet
4. Hot Water or Steam coming out of both the Faucet and the Vent Hole
5. Hot Water coming out of Faucet Vent Hole
6. Restricted Flow of Hot Water
7. Hot Water Drip out of Faucet
8. Dispenses Hot and Cold Water at the same time
9. No cold water available
10. Water does not dispense from unit
11. Cold Water dispenses from Faucet and Vent Outlet Simultaneously
12. Small amount of water periodically dispenses from faucet automatically
13. Dispense Buttons Stick
14. Run-On - Water continues to dispense out of faucet after releasing the dispense button

Also includes related instruction for Hot Tank Descaling

DISPENSING TROUBLESHOOTING

1. Irregular / Intermittent Dispensing from one side

Possible Reason	Solution
<p>Too much water pressure. Recommend 40 to 60 psi for the WL100 Water Treatment System to operate properly.</p>	<p>Check water pressure at the inlet bulkhead with a water pressure gauge.</p> <p>Additional method of verification is to turn off water to unit and press the dispense button. Does the Solenoid open without water pressure to the unit? Listen for Solenoid to activate, not to mistaken for the button “click”.</p> <p>Adjust water pressure to 40-60 psi. <i>The correct input water pressure is critical to the performance of the unit to allow Solenoids to open.</i></p>
<p>Loose or bad connection on the Front Dispensing PCB or Solenoid Connector</p>	<p>Check that they are connected properly and tightened.</p>
<p>Solenoid</p>	<p>If both the Water Pressure and PCB have been ruled out, then it is the Solenoid.</p> <p>Replace Solenoid.</p>
<p>Dispensing button is broken on PCB</p>	<p>Check PCB for loose or damaged button. Replace PCB as necessary.</p>

2. Dispensing Won't Stop When Not Holding the Dispensing Button

Possible Reason	Solution
Too much water pressure. Recommend 40 to 60 psi for the WL100 Water Treatment System to operate properly.	<p>Check water pressure at the inlet bulkhead with a water pressure gauge.</p> <p>Additional method of verification is to turn off water to unit and press the dispense button. Does the Solenoid open without water pressure to the unit? Listen for Solenoid to activate, not to mistaken for the button "click".</p> <p>Adjust water pressure to 40-60 psi. <i>The correct input water pressure is critical to the performance of the unit to allow Solenoids to open.</i></p>
Stem of the switch is broken on the PCB - Printed Circuit Board.	<p>Remove Display PC and inspect switches.</p> <p>Replace Display PCB if switches appear broken.</p> <p><i>Part Number 20-0040 (Factory PN EN-6130)</i></p>
Debris in the Solenoid	Inspect Solenoid for debris and clean out as needed.
Dispensing Button Stuck	Dirt or Foreign material is filling the gap around the push-buttons. Inspect the push buttons and clean surrounding area. Inspect faucet assembly inside the unit and clean as necessary.

3. Steady Drip Out of Faucet

Possible Reason	Solution
Debris in Solenoid	Inspect Solenoid for debris and clean out as needed.

4. Hot Water or Steam Coming out of both the Faucet and Vent Hole

Possible Reason	Solution
Improper Tubing attachment from the Hot Tank to faucet or vice versa.	Check that the Tubing is connected from Tank Outlets to correct Faucet attachments. Connect Tubing to Outlets as needed.

5. Hot Water Coming out of Faucet Vent Hole

Possible Reason	Solution
Too much water pressure. Recommend 40 to 60 psi for the WL100 Water Treatment System to operate properly.	<p>Check water pressure at the inlet bulkhead with a water pressure gauge.</p> <p>Additional method of verification is to turn off water to unit and press the dispense button. Does the Solenoid open without water pressure to the unit? Listen for Solenoid to activate, not to mistaken for the button “click”.</p> <p>Adjust water pressure to 40-60 psi. <i>The correct input water pressure is critical to the performance of the unit to allow Solenoids to open.</i></p>
Improper tubing attachment from the tank to faucet or vice versa.	Verify tubing is connected properly from tank outlets to correct faucet attachments.
Hot Tank outlet hole is scaled over.	<p>Inspect and Descale Tank as needed.</p> <p><u>See Hot Tank Descaling Instructions that are included further below in this Troubleshooting Section.</u></p>
Expansion chamber is not sealed properly.	Replace the Hot Tank.

6. Restricted Flow of Hot Water

Possible Reason	Solution
Partially closed Water Supply Valve to the unit.	Open Water Supply Valve.
Hot Tank outlet hole is scaled over.	Descale Tank. <u>See Hot Tank Descaling Instructions that are included further below in this Troubleshooting Section.</u>
Tubing is creased or has a “kink” in it.	Inspect and replace tubing as necessary.
Faucet nipple screen mesh has obstruction(s)	Unscrew faucet nipple from faucet and remove any obstruction(s) from screen mesh.
Exhausted Filter	Replace the Filter
Solenoid connection to the Display PCB	Turn power off; unplug the unit and visually inspect Solenoid connections into the Display PCB. Verify the soldering points on connections are secure into the board. Remove the PCB to inspect the front of the board.
Solenoid Valve is Malfunctioning	Inspect valve components for proper function. Replace as necessary.

7. Hot Water Drip out of Faucet

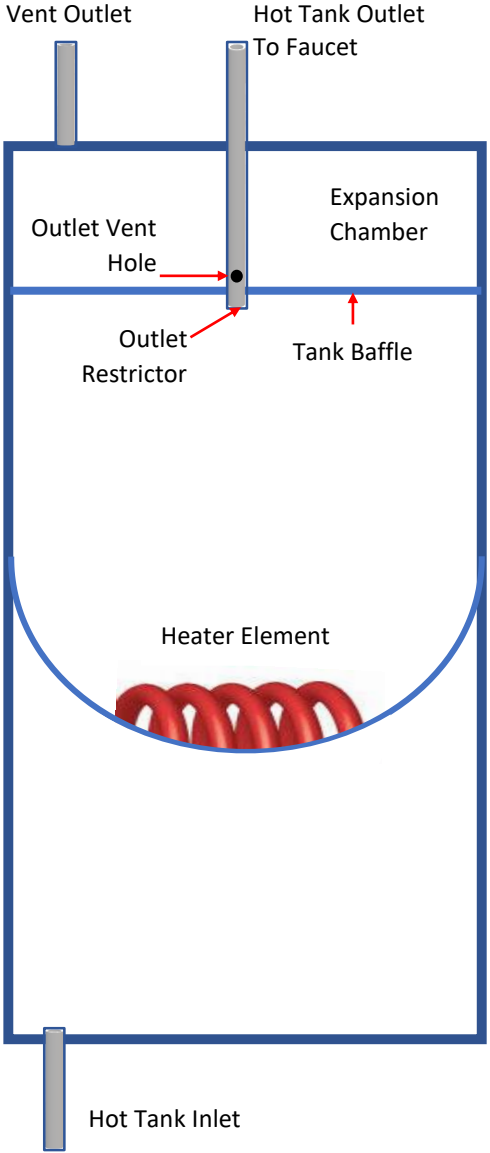
Possible Reason	Solution
<p>Small Outlet Vent Hole susceptible to scale build up.</p>	<p>Descale Tank.</p> <p><u>See Hot Tank Descaling Instructions that are included further below in this Troubleshooting Section.</u></p>
 <p>The diagram illustrates the internal structure of a hot water tank. It shows a vertical 'Hot Tank Inlet' at the bottom left and a 'Hot Tank Outlet To Faucet' at the top right. A 'Tank Baffle' is positioned horizontally across the middle. Above the baffle is an 'Expansion Chamber' and below it is the main reservoir containing a 'Heater Element' (a red coil). A 'Vent Outlet' is located at the top left. A small 'Outlet Vent Hole' is shown on the side of the tank outlet tube, with a red dot indicating a scale buildup. An 'Outlet Restrictor' is located at the base of the outlet tube. Red arrows point from the labels to their respective parts in the diagram.</p>	<p>All Waterlogic Hot Tanks have a built in Vent or Expansion Chamber in the top of the tank except for WL270 (GF) units.</p> <p>The Vent Chamber allows for expansion of the water when it is heated.</p> <p>The chambers are separated by a welded-in tank baffle.</p> <p>Water always flows into the bottom of the tank and out the top to the faucet.</p> <p>The Hot Tank outlet tube has a restrictor in its base. This ensures the reservoir is always full by allowing more water in than out.</p> <p>There is a small hole in the side of the tank outlet tube that allows air and water to pass into the vent chamber as it is heated.</p> <p>Water in the vent chamber is suctioned back through the outlet tube vent hole when water is dispensed.</p> <p>Expansion of water as it is heated in the reservoir will push the water out the faucet when the outlet tube vent hole becomes plugged with debris or scale.</p> <p>The small Outlet Vent Hole is susceptible to scale build up and is a key indicator that descaling is required.</p> <p>It is critical to descale the Hot Tank through the vent line and outlet line on a regular basis to prevent this problem.</p> <p>Descaling through the inlet and/or outlet lines only will not clean the vent chamber and outlet vent hole properly.</p>

8. Dispenses Hot and Cold Water at the Same Time

Possible Reason	Solution
<p>Too much water pressure. Recommend 40 to 60 psi for the WL100 Water Treatment System to operate properly.</p>	<p>Check water pressure at the inlet bulkhead with a water pressure gauge.</p> <p>Additional method of verification is to turn off water to unit and press the dispense button. Does the Solenoid open without water pressure to the unit? Listen for Solenoid to activate, not to mistaken for the button “click”.</p> <p>Adjust water pressure to 40-60 psi. <i>The correct input water pressure is critical to the performance of the unit to allow Solenoids to open.</i></p>
<p>Hot or Cold Solenoid is stuck open.</p>	<p>Remove Top Cover.</p> <p>Check Hot Solenoid: Dispense cold water and visually inspect tubing for water flow from both tanks.</p> <p>Check Cold Solenoid: Disconnect elbow from outlet of cold Solenoid. Select hot water and dispense (quickly releasing dispensing button to avoid much water coming out of cold Solenoid.</p> <p>Replace Solenoid as necessary.</p>

9. No Cold Water Available

Possible Reason	Solution
Too much water pressure. Recommend 40 to 60 psi for the WL100 Water Treatment System to operate properly.	<p>Check water pressure at the inlet bulkhead with a water pressure gauge.</p> <p>Additional method of verification is to turn off water to unit and press the dispense button. Does the Solenoid open without water pressure to the unit? Listen for Solenoid to activate, not to mistaken for the button “click”.</p> <p>Adjust water pressure to 40-60 psi. <i>The correct input water pressure is critical to the performance of the unit to allow Solenoids to open.</i></p>
Closed Water Supply Valve	Open the Water Supply Valve
Cold Water Solenoid Valve malfunction	Inspect the valve components for proper functionality.
Red Heater and Compressor Switch on unit is off.	<p>Turn Red Heater and Compressor Switch on. <i>I = ON</i></p> 
Loose connection(s) on the Display PCB	<p>Turn power off; unplug the unit and visually inspect Solenoid connections into the Display PCB. Verify the soldering points on connections are secure into the board.</p> <p>Remove the PCB to inspect the front of the board.</p>
Exhausted Filter	Replace filters as needed.

10. Water does not dispense from Unit

Possible Reason	Solution
<p>Too much water pressure. Recommend 40 to 60 psi for the WL100 Water Treatment System to operate properly.</p>	<p>Check water pressure at the inlet bulkhead with a water pressure gauge.</p> <p>Additional method of verification is to turn off water to unit and press the dispense button. Does the Solenoid open without water pressure to the unit? Listen for Solenoid to activate, not to mistaken for the button “click”.</p> <p>Adjust water pressure to 40-60 psi. <i>The correct input water pressure is critical to the performance of the unit to allow Solenoids to open.</i></p>
Closed Water Supply Valve	Open the Water Supply Valve.
The unit is not properly plugged into electrical outlet	Check electrical outlet connection, or for blown circuit breaker.
Red Heater and Compressor Switch on unit is in the off position	<p>Turn Red Heater and Compressor switch on. <i>I = ON</i></p> 
15 Amp Fuse Blown	Replace the 15 Amp Fuse as needed.
Hot and Cold Solenoid connections into the Display PCB are loose.	<p>Turn power off; unplug the unit and visually inspect Solenoid connections into the Display PCB. Verify the soldering points on connections are secure into the board.</p> <p>Remove the PCB to inspect the front of the board.</p>
Exhausted Filter	Replace filters as needed.

11. Cold Water Dispenses from Faucet and Vent Outlet Simultaneously

Possible Reason	Solution
Improper tubing attachment from the tank to faucet or vice versa	Verify tubing is connected properly from tank outlets to correct faucet attachments.
Scale has formed inside Cold Tank outlet tube.	Remove Cold Water Outlet Tube from Cold Tank to Faucet, clean or replace as necessary.
Expansion chamber in Cold Tank is not sealed properly.	Replace Cold Tank.

12. Small Amount of Water Periodically Dispenses from Faucet Automatically

Possible Reason	Solution
Too much water pressure. Recommend 40 to 60 psi for the WL100 Water Treatment System to operate properly.	<p>Check water pressure at the inlet bulkhead with a water pressure gauge.</p> <p>Additional method of verification is to turn off water to unit and press the dispense button. Does the Solenoid open without water pressure to the unit? Listen for Solenoid to activate, not to mistaken for the button “click”.</p> <p>Adjust water pressure to 40-60 psi. <i>The correct input water pressure is critical to the performance of the unit to allow Solenoids to open.</i></p>
Cold or Hot Water Solenoid valve malfunction	Inspect valve components for proper function. Replace as necessary.
Obstruction in Solenoid housing is preventing proper sealing of component.	<p>Pre-determine whether water being dispensed is hot / cold. Isolate the water supply; push the DISPENSE button to release the line pressure, and remove the coil affixed to the Solenoid stem.</p> <p>Remove the stem from the Solenoid housing and allow water from the tank to flush out the contaminant(s).</p>

13. Dispense Buttons Stick

Possible Reason	Solution
Dirt or Foreign material is filling the gap around the push-buttons.	<p>Inspect the push buttons and clean surrounding area.</p> <p>Inspect faucet assembly inside the unit and clean as necessary.</p>

14. Run On – Water continues to dispense out of faucet after releasing the dispense button

Reason																														
<p>“Run On” or “Carry On” is present in all Waterlogic pressure fed units without outlet Solenoids.</p> <p>“Run On” is defined is the amount of water that continues to dispense out of the faucet after releasing the dispense button.</p> <p>Run On exists because the tanks pressurize as water is being dispensed. Every Waterlogic tank has an outlet restrictor to ensure the tanks remain full of water and water is controlled as it is released to the faucet. The inlet Solenoid controls flow into the tanks. The tanks will “depressurize” once the dispense button is released the inlet Solenoid closes. A small amount of water will “Run On” through the faucet as the tank depressurizes to atmospheric conditions.</p> <p>Typical “Run On” is 2-3 seconds.</p> <p>“Run On” can be reduced by installing a pressure limiting device.</p> <p>The amount of inlet or supply pressure directly impacts the amount of “Run On” as quantified below.</p>																														
<table border="1"> <thead> <tr> <th colspan="5" data-bbox="180 1514 1349 1545">WLCP Lab Testing of Rn On 7-31-2013</th> </tr> <tr> <th data-bbox="180 1551 370 1583">Pressure</th> <th data-bbox="375 1551 618 1583">Pressure</th> <th data-bbox="623 1551 824 1583">Time</th> <th data-bbox="829 1551 1097 1583">Flow Rate</th> <th data-bbox="1102 1551 1344 1583">Run On</th> </tr> <tr> <th data-bbox="180 1589 370 1621">Static PSI</th> <th data-bbox="375 1589 618 1621">Dynamic PSI</th> <th data-bbox="623 1589 824 1621">4 Liters</th> <th data-bbox="829 1589 1097 1621">l/min</th> <th data-bbox="1102 1589 1344 1621">Seconds</th> </tr> </thead> <tbody> <tr> <td data-bbox="180 1627 370 1659">68</td> <td data-bbox="375 1627 618 1659">40</td> <td data-bbox="623 1627 824 1659">61</td> <td data-bbox="829 1627 1097 1659">2.9508197</td> <td data-bbox="1102 1627 1344 1659">3</td> </tr> <tr> <td data-bbox="180 1665 370 1696">50</td> <td data-bbox="375 1665 618 1696">30</td> <td data-bbox="623 1665 824 1696">72</td> <td data-bbox="829 1665 1097 1696">2.5</td> <td data-bbox="1102 1665 1344 1696">2.5</td> </tr> <tr> <td data-bbox="180 1703 370 1734">32</td> <td data-bbox="375 1703 618 1734">20</td> <td data-bbox="623 1703 824 1734">92</td> <td data-bbox="829 1703 1097 1734">1.956217</td> <td data-bbox="1102 1703 1344 1734">2</td> </tr> </tbody> </table> <p data-bbox="180 1766 1349 1839">Pressure measured at inlet line to unit. Static with unit closed. Dynamic with unit dispensing cold water.</p> <p data-bbox="180 1845 1349 1877">No filters were installed in unit.</p>	WLCP Lab Testing of Rn On 7-31-2013					Pressure	Pressure	Time	Flow Rate	Run On	Static PSI	Dynamic PSI	4 Liters	l/min	Seconds	68	40	61	2.9508197	3	50	30	72	2.5	2.5	32	20	92	1.956217	2
WLCP Lab Testing of Rn On 7-31-2013																														
Pressure	Pressure	Time	Flow Rate	Run On																										
Static PSI	Dynamic PSI	4 Liters	l/min	Seconds																										
68	40	61	2.9508197	3																										
50	30	72	2.5	2.5																										
32	20	92	1.956217	2																										

HOT TANK DESCALING INSTRUCTIONS

The Hot Tank requires removal of mineral deposits (descaling) on a regular basis. Typically descaling should take place every 6 to 12 months to preserve the long-term health of your unit.

Use non-toxic cleaner such as ScaleKleen, DEZCAL, 20% Citric Acid Solution, or Undiluted Vinegar Solution to remove mineral deposits as directed by the manufacturer depending upon filtration and local water conditions.

Descaling is an important process that removes calcium deposits, or scale, that can build up inside a tank over time. Calcium and scale is non-toxic but left unattended will hinder your unit's performance.

⚠️ WARNING! ***PERSONAL PROTECTIVE EQUIPMENT REQUIRED.** Always ensure proper ventilation and use rubber or nitrile gloves and eye protection when using chemicals. Refer to Material Safety Data Sheet for specific requirements of each product.*

⚠️ CAUTION! ***STAINLESS STEEL TANK DESCALING.** The Hot Tank is made from stainless steel. Ensure descaling solution is compatible with stainless and always flush the unit completely. Dispose in an environmentally safe manner.*

Materials Needed:

- Personal Protective Equipment. Rubber or Nitrile Safety Gloves and Protective Eyewear
 - Phillips Screwdriver
 - Temperature Gauge
 - Water Pitcher or Container to collect water from the faucet
 - 19 Liter (5 gallon) container or drain basin
 - Citric Acid Based Cleaner
 - ¼" Plastic Tubing, at least 4 feet in length, and assorted ¼" quick connect fittings
 - Sanitizing Cartridge – an empty Waterlogic Filter with cartridge removed
 - Food Coloring
1. Bypass Filters before starting the Descaling Procedure.
 2. Put descaler per directions and 3 drops of food coloring into the descaling cartridge.
 3. Connect Descaling Cartridge to the inlet water supply and connect to Inlet Bulkhead Fitting on the back of **WL100 Water Treatment System**. Turn on Water Supply.
 4. Select Hot Water and depress the Main Dispensing Button on the Front Control Panel until descaling solution (colored water) comes out of the Faucet. Container and drain basin will be required to catch water from the faucet.
 5. Turn off water supply and remove Sanitizing Cartridge from inlet water supply. Reconnect water supply to Inlet Fitting.

6. Allow descaling solution to remain in the Hot Tank for 15 minutes (length of time may vary depending on water conditions).
7. Place a pitcher, catch basin or other container under the faucet of the **WL100 Water Treatment System**.
8. Flush the Hot Tank until water runs clear.
9. Once clear Water dispenses from the Faucet, the Hot Tank has been descaled. Always ensure unit is performing to the customer's satisfaction.
10. Replace Filters.

 **WARNING! HOT WATER.** *Unit produces Hot Water up to 87°C (189°F). Water above 52°C (125°F) can cause severe burns or scalding. Hot water should be dispensed carefully into insulated container to avoid injury.*

 **CAUTION! MUST REPLACE HOT TANK EVERY 3-5 YEARS DEPENDING ON USAGE.** *The Hot Tank and its controls must be replaced a minimum of every 3-5 years depending on usage to ensure efficient and dependable operation.*

 **WARNING! REINSTALL ALL PANELS AND COVERS.** *Always reinstall all Panels, Protective Covers, and Fasteners after servicing equipment. Failure to do so could result in severe personal injury and will void the certifications and warranty of the equipment.*

COLD WATER TROUBLESHOOTING INDEX

1. Cold Water is not Cold (41° +/- 5° F)

1. Cold Water is not Cold (41° +/- 5° F)

Possible Reason	Solution
No power or refrigeration elements	<p>Check that the Red Heater and Compressor switch is on.</p> <p>Turn Red Heater and Compressor Switch on / = ON</p> 
<p>Tank has run out of cold water.</p> <p><i>Cold Tank capacity is 2 liters (½ Gallon).</i></p>	<p>Wait for Cold Tank to chill water to temperature prior to dispensing more cold water.</p> <p>A greater capacity of Waterlogic Water Systems is available.</p>
Cold Water Thermostat	Check continuity of thermostat with multimeter. Replace thermostat as required.
Refrigerant has run out	Run Compressor for at least ten minutes. If condenser is not warm then refill the refrigerant.
Compressor problem	If Compressor is not running, repair or replacement is needed.

HOT WATER TROUBLESHOOTING INDEX

1. Hot Water is not Hot 85°C ± -15°C (185° ± 5° F)

Also includes related instructions for:

- *Programming - Disabling Energy Saving Sleep Mode*
- *Resetting the Hot Tank Overload or High Limit Safety*
- *Programming - Changing Hot Water Mode to Ambient Water*

1. Hot Water is not Hot 85°C ± -15°C (185° ± 5° F)

The Hot Temperature set point is 85°C (185°F) and is controlled by a thermostat on the side of the Hot Tank.

There is a resettable overload or high limit safety above the thermostat on the side of the Hot Tank that will trip to prevent damage to the unit if the tank is dry heated (turned on without water in it).

The **WL100 Water Treatment System** is programmable to make Cold / Ambient water – refer to Disabling Sleep Mode instructions included further below in this Troubleshooting Section.

The **WL100 Water Treatment System** does NOT have Extra Hot capability and the maximum hot temperature is 87°C (189°F).

It typically takes 10 minutes for the 500W to heat the 1.6 Liter (0.4 Gallon) of room temperature (ambient) water to the 85°C (185°F) set point.

Possible Reason	Solution
No power to Heater elements	<p>Check that the Red Heater and Compressor switch is on.</p> <p>Turn Red Heater and Compressor Switch on. <i>I = ON</i></p> 
Is unit in sleep mode?	<p>If no water has been dispensed for 3 or more hours, unit goes into sleep mode. Dispense hot water, wait 5 minutes, check temperature.</p> <p>If unit still does not heat proceed to “No power to Heater elements” below.</p> <p><u>If unit does heat but you would like to Disable Sleep Mode, refer to the instructions included further below in this Troubleshooting Section</u></p>

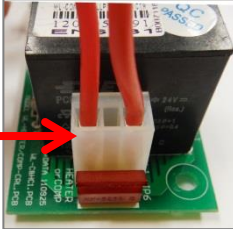
<p>Hot Tank Overload Tripped</p> <p><i>Overload is a safety feature to ensure the tank does not overheat.</i></p>	<p>Overload will “click” when pushed. The overload is automatically reset when pressed.</p> <p><u>See Resetting the Hot Tank Overload or High Limit Safety Instructions that are included further below in this Troubleshooting Section</u></p>
<p>Energy Saver PCB Relay Board Connector Bad</p>	<p>Inspect connector for discoloration. If there is no discoloration, contact Waterlogic Technical Department.</p> 
<p>Thermostat or overload “open” on Hot Tank</p>	<p>Turn Power off. Check OHM’s resistance across terminals on each Thermostat and Overload separately.</p> <p>Good components will indicate a closed circuit or zero OHM’s on the meter.</p> <p>Replace components as necessary.</p>
<p>Loose or improperly connected wire(s) to the heating element / Hot Tank.</p>	<p>Visually inspect wire leads going to the Hot Tank; confirm proper connections to the heating elements.</p> <p>Hot Tank life is 3-5 years depending on usage, depending on usage.</p> <p><i>*Typically, dealers swap out the Hot Tank at site, take back to the shop to repair.</i></p>
<p>Heating Coil Not Working</p>	<p>Turn Power off; Drain Hot Tank; Use multi-meter to check Heater element for approximately 26 OHM’s resistance.</p> <p>Hot Tank must be empty if you are checking for continuity.</p> <p>Replace Hot Tank as necessary.</p>
<p>Improper Jumper Settings</p>	<p>The unit has been changed to a cold/ambient setting (JP9 has been moved from Pin 1 and Pin 2).</p> <p>Verify that Jumper Pins are located properly for Hot Water Option.</p> <p><u>See Changing Hot Water Mode to Ambient Water Instructions included further below in this Troubleshooting Section</u></p>

PROGRAMMING “DISABLING ENERGY SAVING SLEEP MODE”

All **WL100 Water Treatment Systems** come from the factory with Energy Saving Sleep Mode engaged to meet the Energy Star Certification requirements. Energy Star Sleep Mode disables the Heater Circuit if the hot dispense has not been used for 3 hours.



Selecting any button "wakes up" the **WL100 Water Treatment System** and turns the Heater circuit back on. The Hot Tank will typically take less than 10 minutes to heat the water from ambient to the 85°C (185°F) set point.

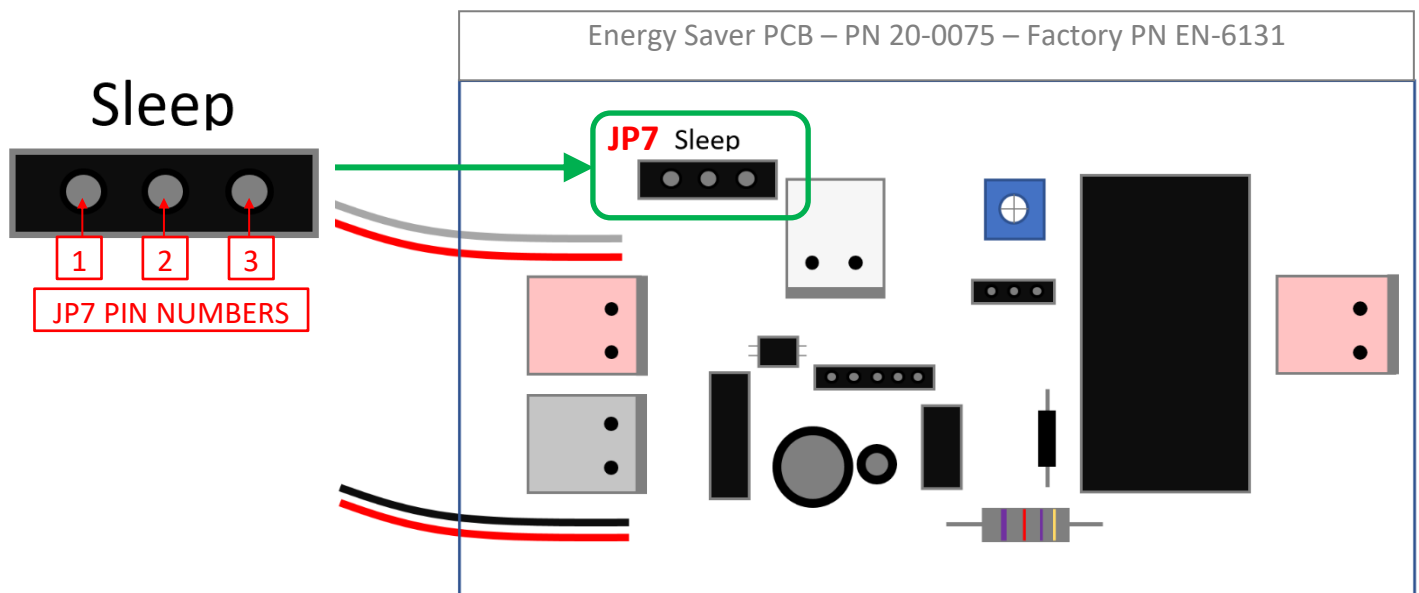

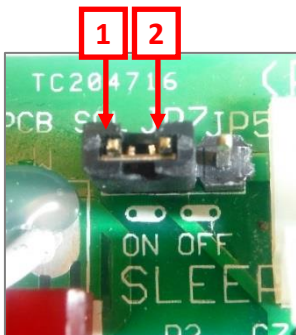
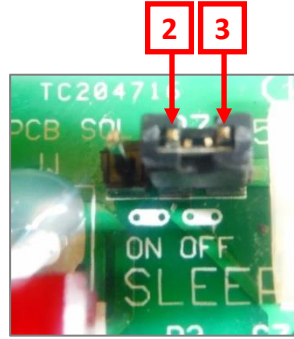

Unplug Power Cord and remove Top Cover to access Energy Saver PCB.

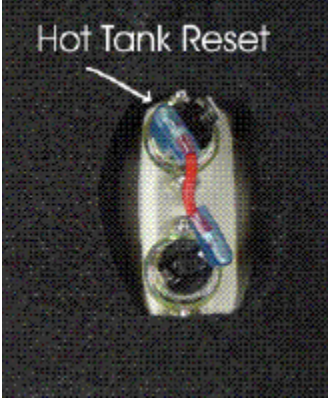

ENERGY SAVING SLEEP MODE	
ON	OFF
PCB Jumper JP7 (Pin Numbers 1 and 2) 	PCB Jumper JP7 (Pin Numbers 2 and 3) 

RESETTING THE HOT TANK OVERLOAD OR HIGH LIMIT SAFETY

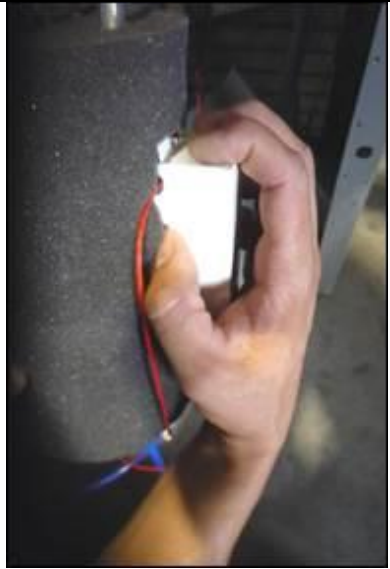
1.	Red Compressor/Heater Switch must be in the <i>O=OFF</i> position	
2.	Unplug the Power Cord from rear of unit.	
3.	Remove the Lower Front Panel of unit by removing the Phillips head screws underneath the Lower Front Panel.	
4.	Locate the Protective Metal Box on the rear of the Hot Tank. As you look through the Condenser coils on the rear of the unit, you will see the Hot Tank located on the right-hand side.	
5.	<p>From the front of the WL100 Water Treatment System, reach up behind the Hot Tank and take hold of the Protective Metal Box covering the Thermostat and overload on the Hot Tank.</p> <p>There are nuts that secure the Protective Metal Box to the Hot Tank, are loose enough to allow you to remove the Protective Metal Box.</p> <p>If the nuts on the metal box are too tight, loosen the nuts securing the Hot Tank to the Upper Base of the WL100 Water Treatment System unit and lower the Hot Tank so you can remove the Protective Metal Box.</p>	

<p>6.</p>	<p><i>For demonstrative purposes, photos below have lowered the Hot Tank from the unit.</i></p> <p>Press the reset button</p>	 
<p>7.</p>	<p>Reattach the Protective Metal Box by depressing the top flap of the Protective Metal Box so it snaps back into its original position on the Hot Tank.</p>	
<p>8.</p>	<p>Replace the Lower Front Panel.</p>	
<p>9.</p>	<p>Plug in the Power Cord.</p>	
<p>10.</p>	<p>Turn on the Red Compressor/Heater Switch <i>I=ON</i> position</p> <p>The Hot and Cold Tanks must be filled with water BEFORE turning on the Red Heater and Compressor Switch.</p>	
<p>11.</p>	<p>Verify the cooler is fully operational before installing it at the customers' site.</p>	

PROGRAMMING “CHANGING HOT WATER MODE TO AMBIENT WATER”

The **WL100 Water Treatment System** comes with set to Hot / Cold, which can be changed to Ambient / Cold settings. On the Energy Saver PCB, move the Jumper on JP9 from Pins 1 and 2 to Pins 2 and 3.

Unplug Power Cord and remove Top Cover to access Energy Saver PCB.

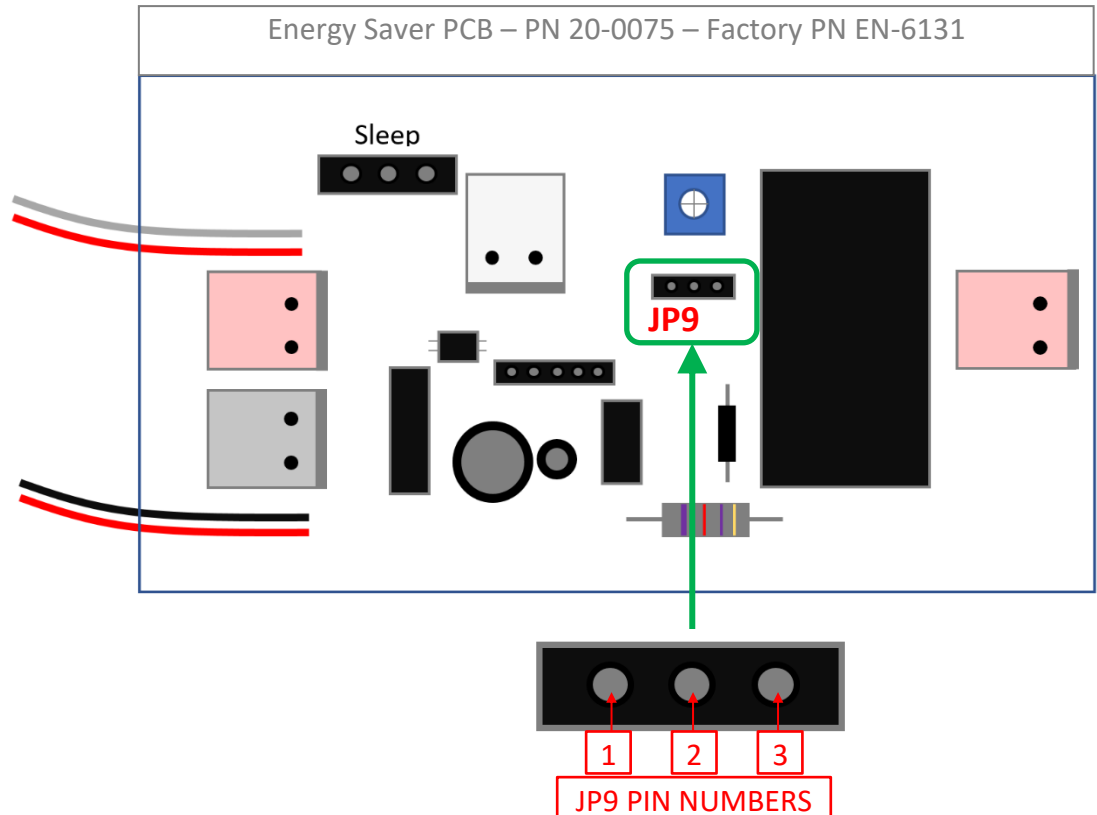

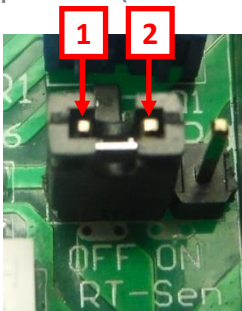
Hot and Cold (Factory Settings)	Ambient and Cold
PCB Jumper JP9 (Pin Numbers 1 and 2) 	PCB Jumper JP9 (Pin Numbers 2 and 3) 