

WL30-RO

MANUAL



Quench USA Inc.
630 Allendale Road, Ste 200
King of Prussia, PA 19406
(855) 558-9796 www.Waterlogicwater.com

WL30-RO MANUAL

Congratulations on your choice of the **Waterlogic WL30-RO Water Dispenser**. The **WL30-RO** model dispenses highly filtered hot and cold water. The **Waterlogic WL30-RO Water Dispenser** provides exceptional quality and great tasting water with every use.

INTRODUCTION

Carefully read and follow all instructions to ensure proper and efficient operation of your **Waterlogic Water Dispenser**. Contact your **Authorized Waterlogic Dealer** if you have any questions.

Waterlogic and **Authorized Waterlogic Dealers** employ trained service personnel who are experienced in the installation, function, and repair of this equipment. This publication is written for use by these qualified individuals. **Waterlogic** encourages users to learn about products, however, we believe that product knowledge and service is best obtained by consulting your **Authorized Waterlogic Dealer**.

Waterlogic Water Dispensers should be combined with selected water treatment components to create a system specifically tailored for each application by trained and qualified personnel.

Products manufactured and marketed by **Waterlogic** and its affiliates are protected by patents issued or pending in the United States and other countries.

Waterlogic reserves the right to change the specifications referred to in this literature at any time, without prior notice. Changes or modifications not expressly approved by **Waterlogic** could void the warranty and user's authority to operate the equipment.

TABLE OF CONTENTS

USER GUIDE

- Safety Alert Symbols 4
- Safety Precautions 4
- Features and Benefits 6
- Certifications 7
- Model Designations, Consumables, & General Specs 8
- Shipping Specifications 9
- Receiving Your Equipment 10
- Control Panel & Operating Instructions..... 11
- Settings Using the User Interface 12
- Warranty 13

SERVICE GUIDE

- Service Requirements 14
- WL30-RO Parts Diagram 15
- Flow Diagram 21
- Electrical Diagram 22
- Dipswitch Settings..... 23

INSTALLATION GUIDE

- Pre-Installation Procedures 24
- Notes on Installation 25
- Filter Flushing Procedure 26
- Installation 30
- PM Guide 33
- Resetting the Hot Tank Overload Thermostat..... 35
- Final Inspection 36

MAINTENANCE

- Preventative Maintenance 37
- System Inspection 38
- Warranty Procedure 38

TROUBLESHOOTING

- Troubleshooting Guide 39

SAFETY ALERT SYMBOLS

Read and follow all safety information carefully. The signal words used in this manual are selected as shown below and based on an assessment of the degree of potential injury or damage (severe or minor) and the occurrence of injury (occurs or has the potential to occur) when the warning is ignored:

⚠ DANGER!

Indicates a situation which, when not avoided, results in death or severe injury.

⚠ WARNING!

Indicates a situation which, when not avoided, has the potential to result in death or severe injury; and/or severe property damage.

⚠ CAUTION!

Indicates a situation which, when not avoided, results in or has the potential to result in minor injury; and/or minor property damage.

SAFETY PRECAUTIONS

Basic safety precautions should be followed, including the following:

Ensure all Local, State, and Federal Laws and Codes including health and safety guidelines are met when installing **Waterlogic** Equipment. Only qualified service technicians should attempt installation and service of **Waterlogic** Equipment. Always read the entire operating instructions before using the appliance and save these instructions for future use.

⚠ DANGER! *This product can cause death or severe injury if incorrectly operated, installed or maintained. The installation, maintenance, sanitizing and any repair must be performed by qualified persons trained by Waterlogic International or their approved distributors only. Do not remove any panel or cover to protect against electrical shock and exposure to UV radiation.*

⚠ DANGER! **ELECTRICAL SHOCK HAZARD.** *Always use a dedicated and properly grounded outlet. Unit should be protected by ground-fault circuit interrupter (GFCI) or residual current device (RCD) having a rated residual operating current not exceeding 30mA. Use only **Waterlogic** supplied power cord. Never use extension cords or power strips to connect unit. Do not use if the power supply cord is damaged. Always unplug from power supply prior to servicing.*

⚠ WARNING! **AUTHORIZED USE ONLY.** *This appliance is to be used for its intended purpose as described in this manual. Untrained individuals who use this manual assume the risk of any resulting property damage or personal injury. This appliance can't be used by children and persons with reduced physical, sensory, or mental capabilities or lack of experience.*

⚠ WARNING! **DO NOT OPERATE IF DAMAGED.** *Unplug and isolate water supply if abnormal conditions exist. Contact Waterlogic or authorized dealer for repair, service, and installation to avoid hazards.*

⚠ WARNING! **HOT WATER.** *Unit produces Hot Water in excess of 80°C (175°F). Water above 52°C (125°F) can cause severe burns or scalding. Keep unauthorized people and children away from the unit to avoid accidental dispensing of hot water.*

⚠ WARNING! **CONNECT TO POTABLE WATER SUPPLY.** *This system is to be used for water only and is NOT intended for use where water is microbiologically unsafe or with water of unknown quality without adequate disinfection before or after the system.*

- ⚠ WARNING! TIP HAZARD.** Dispenser could tip or fall causing serious injury if installed with a base. Always install unit on a firm, flat, and level surface and secure unit to cabinet, wall, or floor if needed and secure to the base, if applicable. Never place heavy items on top of unit and never climb, stand, or hang on unit or storage cabinet to prevent injury and damage.
- ⚠ WARNING! UNIT IS HEAVY. TWO PERSON LIFT REQUIRED.** Transport unit empty and always use material handling equipment or two people with proper lifting technique to reduce injury risk.
- ⚠ WARNING! STORE AND TRANSPORT UNIT EMPTY. ALWAYS SANITIZE BEFORE USE.**
The unit must be completely drained before storing to avoid stagnation and reduce microbiological contamination (potential bacterial growth). Always sanitize before use to eliminate any potential microbiological contaminants.
- ⚠ CAUTION! INDOOR USE ONLY.** Intended for Household Use. Never expose to direct sunlight, heat sources, or ambient air temperature above 37°C (100°F) or below 2°C (35°F). Install indoors and keep unit away from excessive humidity or rain. Never expose to freezing temperatures. Ensure there is adequate clearance around the unit to allow refrigeration system condenser to dissipate heat. Warmer environments require more clearance around the unit. Minimum clearance around all surfaces of the machine is 2-inches. Installs where the ambient temperature exceeds 27°C (80°F), require a minimum of 4-inches clearance for proper heat dissipation and efficient operation.
- ⚠ CAUTION! USE A WATER PRESSURE REGULATOR.** Waterlogic will not be responsible for injury or damage caused by excessive water pressure. Input or feed pressure must be 40 psi to 80 psi. Be aware of any potential pressure surges caused by building/municipal pumping stations. Failure to comply will void all warranties. The manufacturer accepts no liability for damage caused by excessive water pressure.
- ⚠ CAUTION! USE UV STABILIZED SUPPLY LINES.** Feed the unit with a potable ambient or cold-water supply only. Feed water over 37°C (100°F) can damage the treatment components. Water block devices and external leak detectors are strongly recommended. Locate the unit as close to the water supply and the electrical connections as possible. Immediately isolate or close water supply valve and contact service representative if leak is noticed.
- ⚠ WARNING! REFRIGERANT SYSTEM.** This system is manufactured with 134A refrigerant. Repairs to the refrigeration system must be performed by a certified refrigeration technician only.
- ⚠ CAUTION! DO NOT PLACE HEAVY ITEM OR WATER CONTAINER ON TOP OF UNIT.** Water may leak into the electrical system causing a fire hazard. Heavy items may fall off causing injury.

Contact Waterlogic for assistance or help finding an Authorized Service Representative.

WL30-RO FEATURES AND BENEFITS

Hot and Cold Water

The *WL30-RO Water Dispenser* produces Hot and Cold water to meet customer demands.

High Capacity and Fast Flow

The *WL30-RO Water Dispenser* holds 0.5 gallons of Hot Water and 1.6 gallons of Cold Water, and can dispense Cold Water at 2 L/m, double the rate of a traditional cooler.

Large Dispense Area with Recessed Faucet

11-inch dispense height with recessed faucet to protect from cross-contamination.

Leak Prevention

WL30-RO Water Dispensers are supplied with a leak stop device to cut off the water supply in the case of a water leak or overflow.

Touch Sensor Dispense

Touch Sensors are used to activate dispense and select functions.

Drip Tray with “Tray Full” Indicator

Unit comes with a high-capacity Drip Tray with an indicator for when the tray needs to be emptied.

RO Water Filtration

The *Waterlogic WL30-RO* uses a 5-stage RO filtration configuration for great tasting water.

UV Light in Tank

The *Waterlogic WL30-RO* uses LED UV technology to help maintain cleanliness inside the tanks.

Surface Protection Technology

The *Waterlogic WL30-RO* has key surfaces surrounding the dispensing area that are infused with surface protection technology, inhibiting growth of odor and stain-causing microbes, like bacteria and mold.

CERTIFICATIONS

WL30-RO Water Dispensers have been tested and certified to rigorous NSF and UL Standards. We believe that performance testing and certifications validate **Waterlogic** as a world-leader in Water Dispensers.

Waterlogic WL30-RO Component Certifications Include:

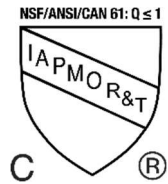

The **Waterlogic WL30-RO** with WLPC-12 is certified by IAPMO R&T against NSF/ANSI/CAN 61: Q_{≤1}, NSF/ANSI 372, NSF/ANSI 58, and CSA B483.1 for the specific performance of material safety, structural integrity, and lead-free requirements as verified and substantiated by test data. The WL30-RO System is also certified to NSF/ANSI-42 for the reduction of Chloring and Taste & Odor when using the Waterlogic WLPC-12 filter.



UL399 – Certified Drinking Water Cooler

Intertek Labs (ETL) Certified the **Waterlogic WL30-RO** to ANSI/UL 399 Standard for Drinking Water Coolers.

CSA C22.2 No. 120 CSA Standard for Refrigeration Equipment

MODEL/PART DESIGNATIONS

BRAND NAME	DESCRIPTION	MODEL - PART NUMBER
<i>WL30-RO</i>	<i>WL30-RO</i> – Hot & Cold Tower	WL30-RO
	Serial#: WL030FMB0E0XXXXX	

CONSUMABLES

FILTER	REPLACEMENT FREQUENCY	PART NUMBER
SEDIMENT FILTER	6-12 MONTHS	WL-QC1
POST-CARBON FILTER	6-12 MONTHS	WL-QC5
RO MEMBRANE	TEST TDS REDUCTION AT 12 MONTHS	WL-QC3R
PRE-CARBON FILTER	1,500 Gallons	WL-QC2
MINERAL ADD-BACK FILTER (RO)	6-12 MONTHS	WL-QC4R
AIR FILTER	3 YEARS	AF

SPECIFICATIONS

<u>ITEM</u>	<u>WL30-RO</u>
Water Connection	¼" Quick Connect
Cold Temperature Settings	35/39°F (default set at 39°F)
Hot Temperature Settings	185°F
Recommended Service Water Pressure	60-70psi (4.2-4.9kgf/cm ²)
Flow Rate	0.5 GPM
Rated Voltage	AC 110V/60Hz @ 4.9Amps
Power Consumption	1.60kWh/24hrs
Power Cord	1.9m (6.3ft)
IP Class	IPX1
Climate Class	N Class (32°C +/- 1°C) (89.6°F +/- 33.8°F)
Safety Device	Overheating protector. Leak Stop Device. Fuse.
Hot Tank Capacity	0.5gal (1.9L)
Cold Tank Capacity	1.6gal (6.1L)
Environmental Temperature	Max: 90°F (32°C) Min: 35°F (2°C)
Source Water Temperature	Max: 90°F (32.2°C) Min: 40°F(4.5°C)
Relative Humidity	55% at 78°F(25.5°C)
Refrigerant Gas	R134a (1.34oz +/-0.03oz)
R134a Pressures	280psi (19.3bar) High Side, 88psi (6.1bar) Low Side

SHIPPING SPECIFICATIONS

<u>ITEM</u>	<u>WL30-RO</u>
Width/Depth/Height	11.8"W x 17.2"D x 50.3"H
Dispense area Height	11"
Weight (dry)	58lbs

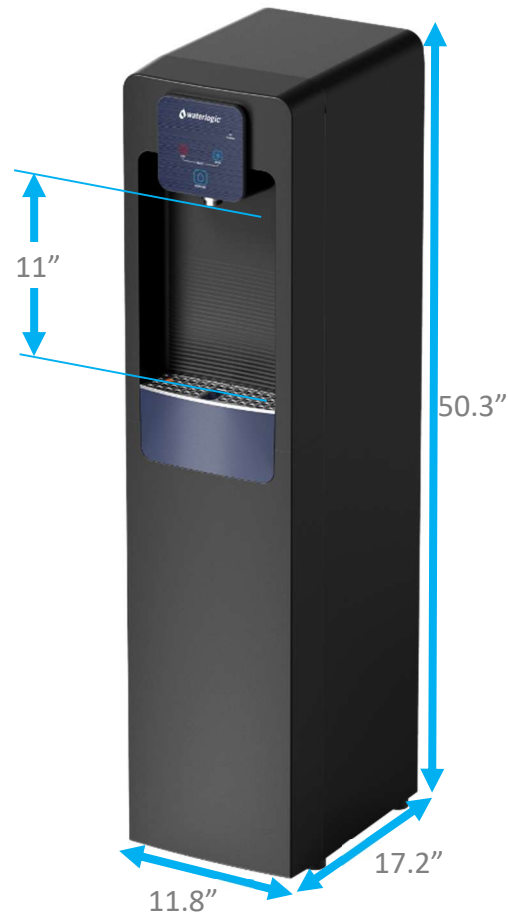

RECEIVING YOUR EQUIPMENT

Upon receipt of your equipment, you should check the following:

1. Are the systems still on the pallet?
2. Confirm the number of boxes you are signing for.
3. Is there any obvious damage to the product or the boxes?

If there are any discrepancies or any obvious damage to the equipment or boxes, please note it on the “Bill of Lading” and/or refuse the shipment.

After receiving the equipment from the carrier, remove packaging and inspect for any hidden freight damage. If freight damage has occurred, call the freight company and customer service (800) 288-1891 to report the damage. Photograph all damages to be submitted with the claim. **THIS MUST BE DONE WITHIN FIVE BUSINESS DAYS OF DELIVERY.** If not reported within 3 business days, Waterlogic and/or carrier will not be responsible for replacement or repair.

CONTROL PANEL & OPERATING INSTRUCTIONS

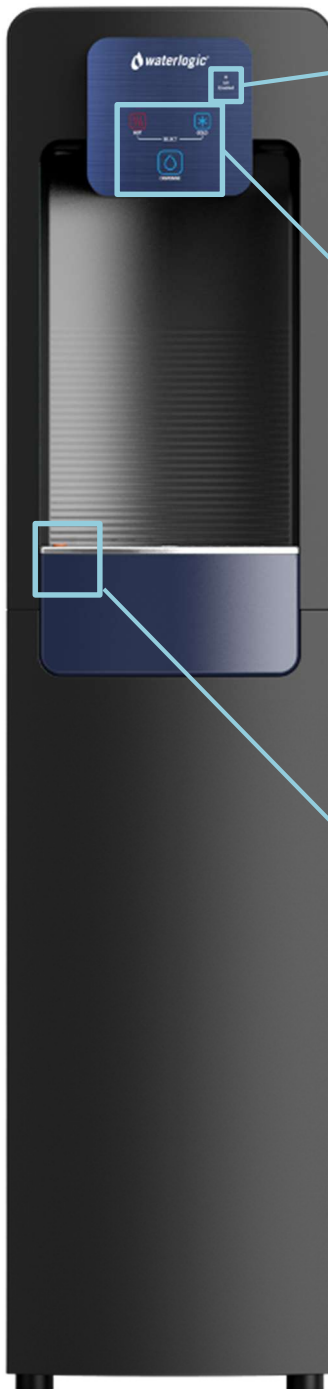

- **UV Enabled**: This light indicates the units UV lights are active and working properly.

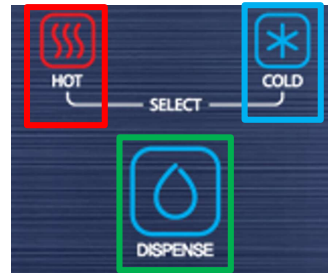

- **Hot Select Sensor**: The left touch sensor is used to select hot water for dispense.
- **Cold Select Sensor**: The right touch sensor is used to select cold water for dispense. This is the default selection.
- **Dispense Sensor**: The central touch sensor is used to dispense water at the selected temperature.

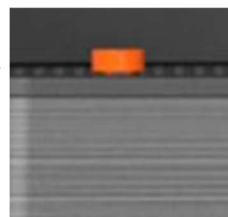

- **Drip Tray "Full" Indicator**: This small float protrudes from the drip tray grill if the water level rises too high. An indication that the tray needs to be emptied.

SETTINGS USING THE USER INTERFACE

Several settings and functions can be accessed through the User Interface (UI) of the **Waterlogic WL30-RO**. This section will detail what those settings are and how they can be accessed.

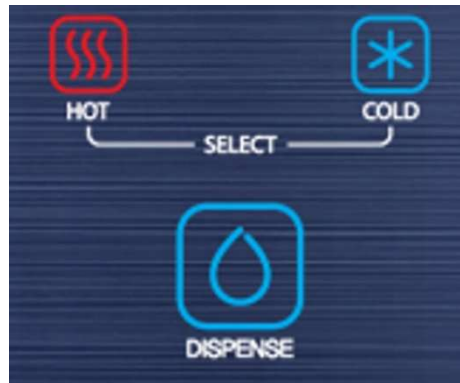

Filter Reset

To reset the internal filter timer, perform the following sequence:

1. Touch and release “Hot Select,” then touch and release “Dispense” 5 times.
2. Simultaneously touch and release “Hot Select” and “Cold Select.”
3. Touch and release “Cold Select,” then touch and release “Dispense.”

How to Turn Off the “Chime”

To silence the unit during operation (disabling the “chime”) perform the following sequence:

1. Touch and release “Hot Select,” then touch and release “Dispense.”
2. Touch and release “Cold Select,” then touch and release “Dispense” 5 times.

WATERLOGIC MANUFACTURED WATER DISPENSER LIMITED WARRANTY

The Waterlogic WL30-RO is covered by the Waterlogic Warranty for a period of 5 years from the date of purchase against manufacturer defects given the filtration is changed with Waterlogic branded filters on the recommended schedule.

General Provision and Exclusions:

This warranty only applies in the fifty (50) United States and Canada. This warranty does not apply, and no agreement, whether written or implied, shall be applicable if the affixed serial number is removed, defaced, or obliterated. This warranty does not apply to the filters after exposure to water. Refer to service manual for filter requirements and expected performance. This warranty does not apply if parts used as original or replacement equipment, including filters, are not obtained, or authorized through WATERLOGIC, and such unauthorized usage shall void this warranty. This warranty does not apply to any wetted parts that become inoperative due to lime, scale, or other water quality conditions. This warranty does not apply to any machine or components that have become inoperable due to a failure by Dealer/Distributor or the end-user to satisfy standards or regulations adopted by any governmental agency. This warranty does not cover performance, failure or damages of any part resulting from external causes such as alterations, abuse, misuse, misapplication, neglect, accident, installation, operation contrary to printed material, corrosion or acts of God.

This warranty only applies to the operative components of the machine and does not apply to the exterior shell or frame to which the shell is attached and the appearance of the machine.

This warranty and any applicable industry certifications for this machine are automatically voided if the machine is altered, modified, or combined with any other machine, equipment, or device. Alteration or modification of the machine may cause serious flooding and/or hazardous electrical shock or fire. Except as set forth herein, WATERLOGIC makes no other warranty, guarantee or agreement expressed, implied or statutory, including any implied of merchantability or fitness for a particular purpose.

The foregoing is in lieu of all other agreements expired or statutory and all other obligations or liabilities of WATERLOGIC. WATERLOGIC does not assume or authorize any person to assume any obligations of liability in connection with this product. In no event will WATERLOGIC be liable for special, incidental, consequential, or punitive damages, or for any delay in the performance of this warranty agreement due to causes beyond its control.

Export Warranty:

The WATERLOGIC export warranty shall apply to all area outside of the Continental limits of the United States and Canada. The export warranty shall mirror the domestic warranty set forth above in all respects except that a) the export warranty shall be limited to the Initial Term and there is no coverage for the additional warranty through the first year and b) the Dealer/Distributor shall be responsible for all transportation charges to implement the repairs.

ALL WARRANTY REPAIRS SUBJECT TO PRIOR APPROVAL BY THE WATERLOGIC SERVICE DEPARTMENT IN ORDER TO VALIDATE THAT THE DEFECTIVE COMPONENT IS STILL UNDER WARRANTY.

SERVICE REQUIREMENTS

⚠ WARNING! *Read and understand the contents of this manual before attempting to service the WL30-RO Water Dispenser. Failure to follow the instructions in this manual could result in death, serious personal injury, or severe property damage. Only trained and qualified technicians should attempt to install, maintain, or service Waterlogic Equipment.*

1. Visually inspect all electrical and water connections for signs of wear or damage.

⚠ DANGER! ***HIGH VOLTAGE ELECTRICAL HAZARD.** Unplug before inspection and service.*

⚠ WARNING! ***ULTRAVIOLET RADIATION.** Protect your skin and eyes against ultraviolet rays. Never look directly at an operating UV light. Disconnect before removing UV Lamp.*

⚠ CAUTION! ***UV LIGHTS ARE HAZARDOUS.** Lamps are considered Hazardous Waste and must be disposed of accordingly. Refer to Product MSDS sheet for details.*

2. Ensure there is adequate (minimum of 5") clearance around the **WL30-RO Water Dispenser** and clean the condenser grill to provide efficient cooling system operation.
3. Sanitize the unit per instructions in the sanitization procedures.

⚠ WARNING! ***SANITIZER MAY CONTAIN HAZARDOUS CHEMICALS.** Use of proper personal protective equipment such as rubber gloves and eye protection are required.*

4. Clean and sanitize external surfaces of the **WL30-RO Water Dispenser**. Use soap and water or chemicals that are compatible with ABS plastic and will not damage or degrade the product surfaces.
5. Remove and clean the Faucet. Replace as needed.
6. Flush in filters per instructions, and change filters on predetermined schedule, commonly every 12 months for standard filters.

WL30-RO PARTS DIAGRAM

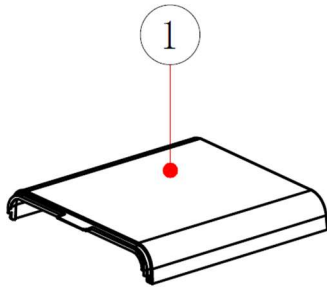

1	PA018A01	Top Lid
----------	-----------------	----------------

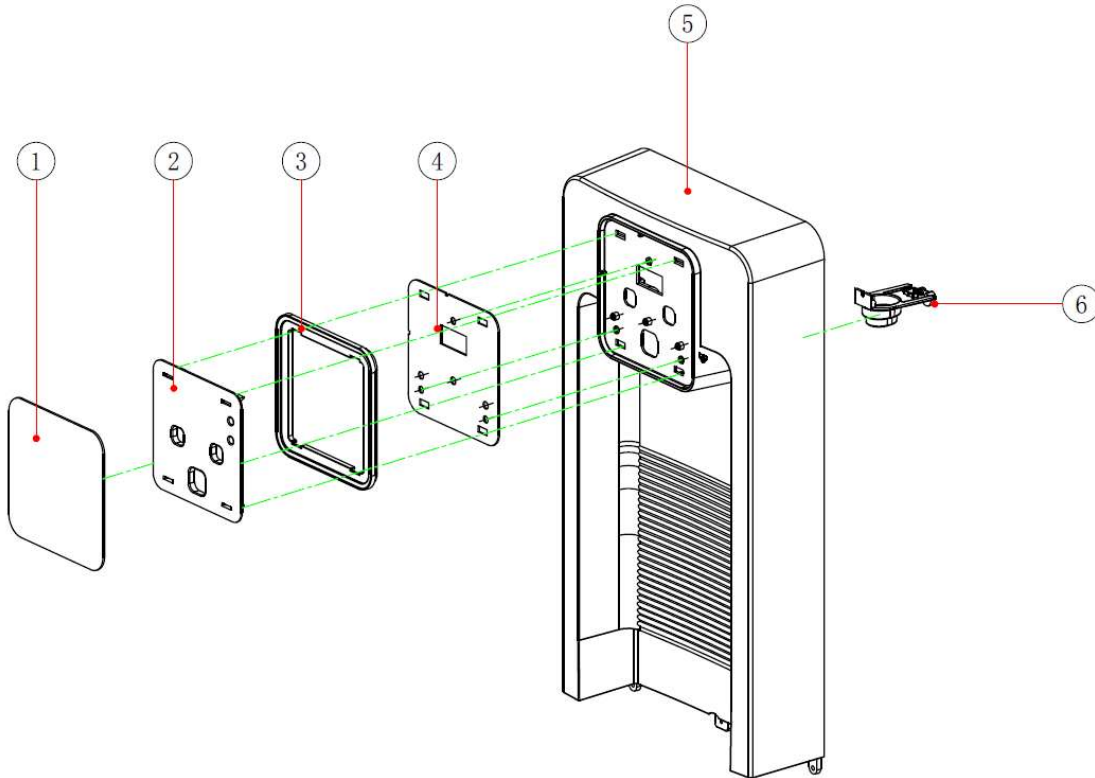

1	PH044A01	Face Plate WL30
4	EB083A01	Front LED PCB
5	PB036A01	Upper Front Panel
6	PK128A01	Dispense Cover

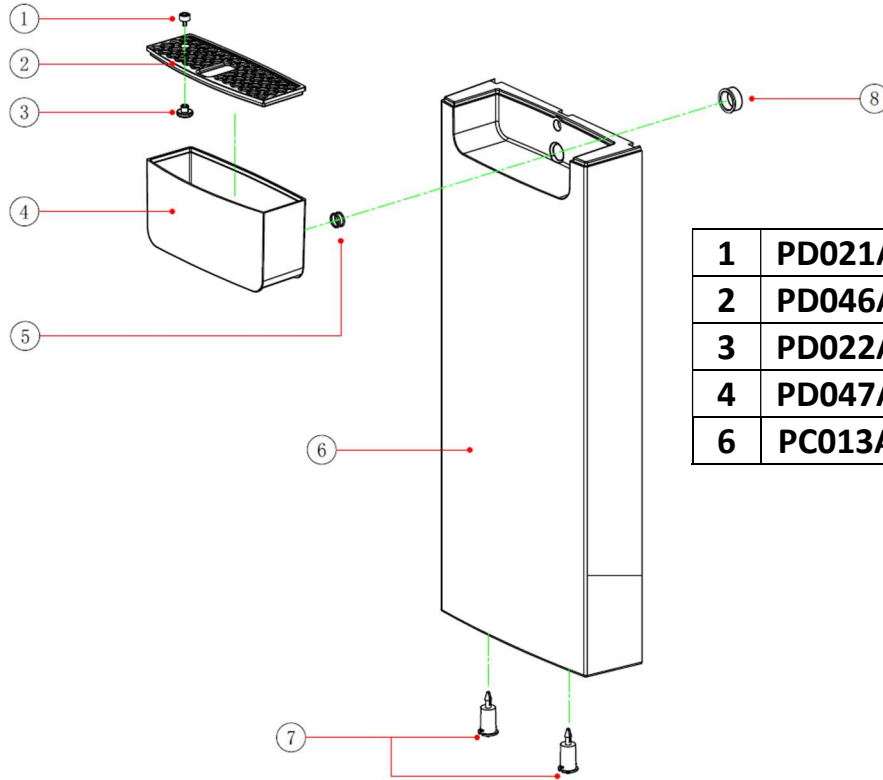

1	PD021A01	Drip Tray Float Cover
2	PD046A01	Drip Tray Grill
3	PD022A01	Drip Tray Float
4	PD047A01	Drip Tray
6	PC013A01	Lower Front Panel

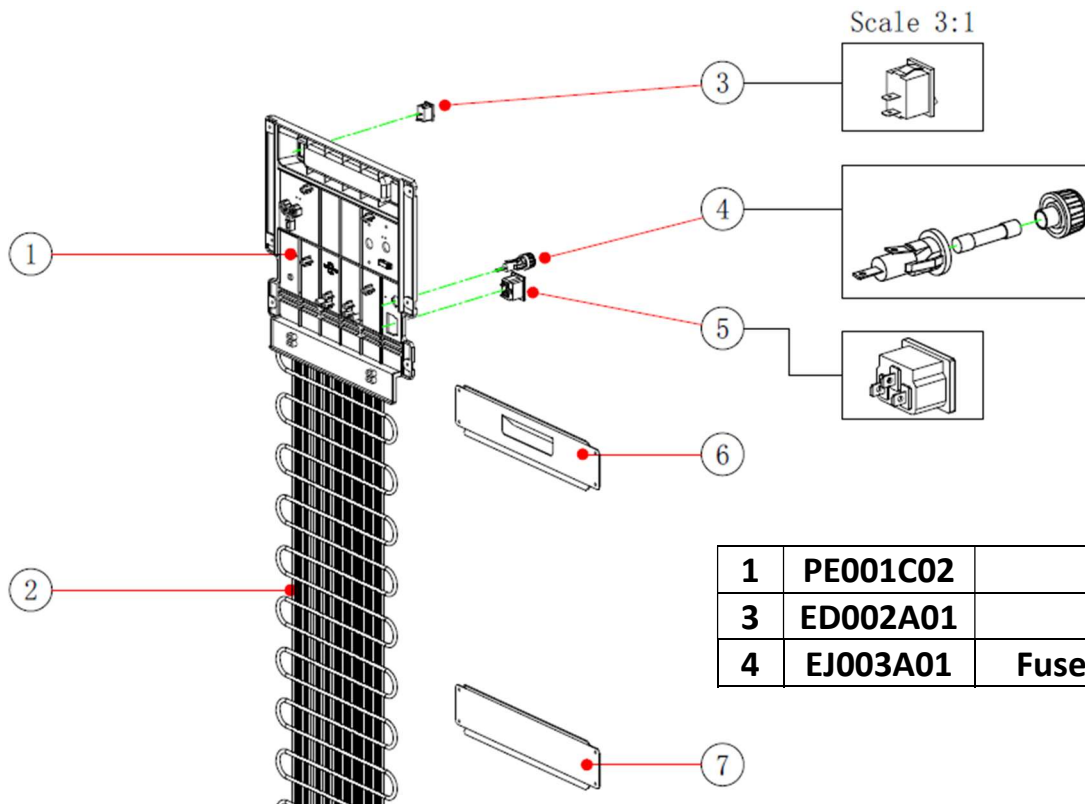

1	PE001C02	Rear Panel
3	ED002A01	Hot Switch
4	EJ003A01	Fuse Housing & Cap

1	IA001D01	Side Panel
2	PK063A01	Drain Valve Body
3	PK063B01	Drain Valve Cap
4	PK071A01	PCB Case Top
5	EB085A01	Main PCB
6	PK070A01	PCB Case Bottom
8	PF003A01	Bulkhead Fitting
14	EE011A01	Hot Water Pump

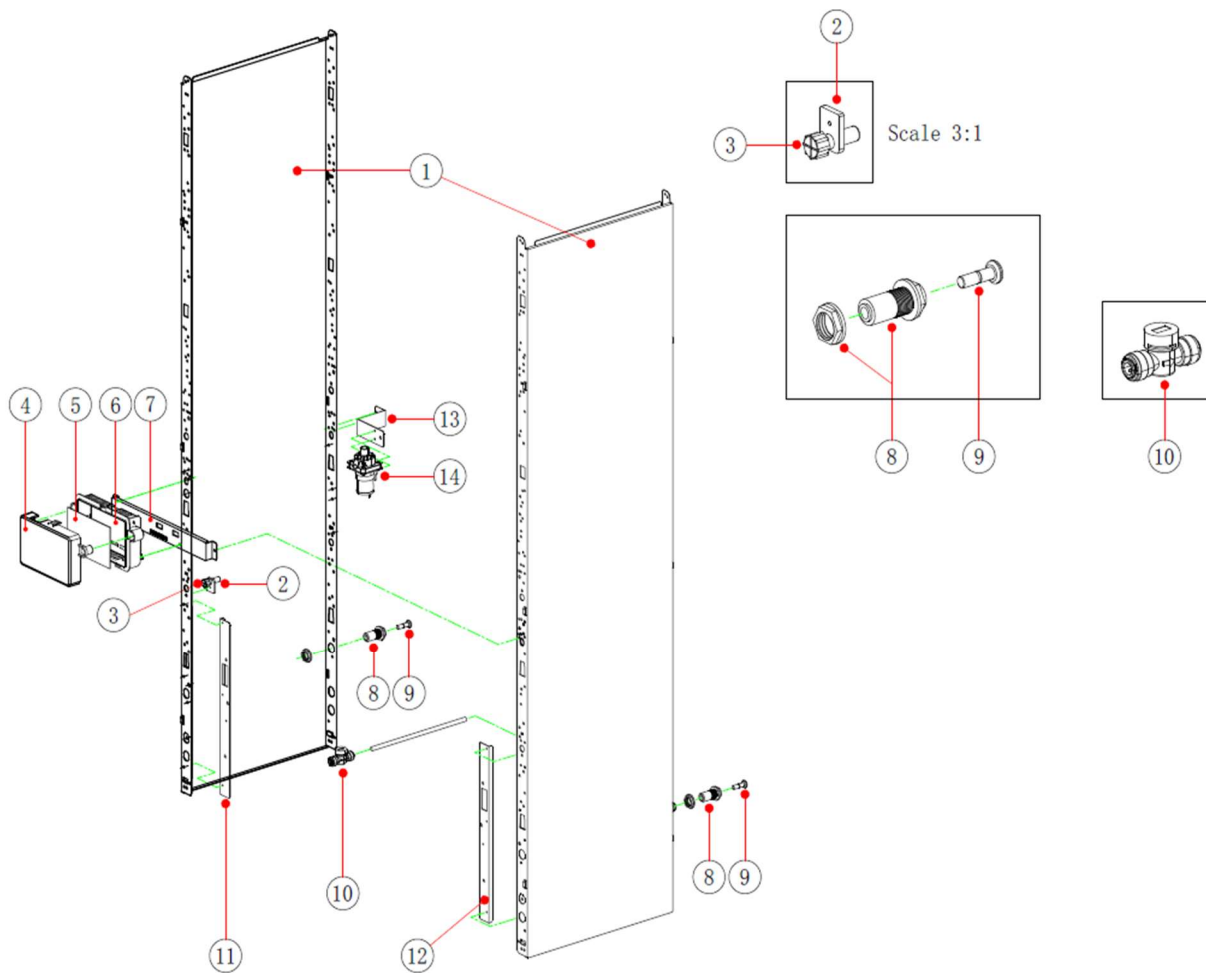

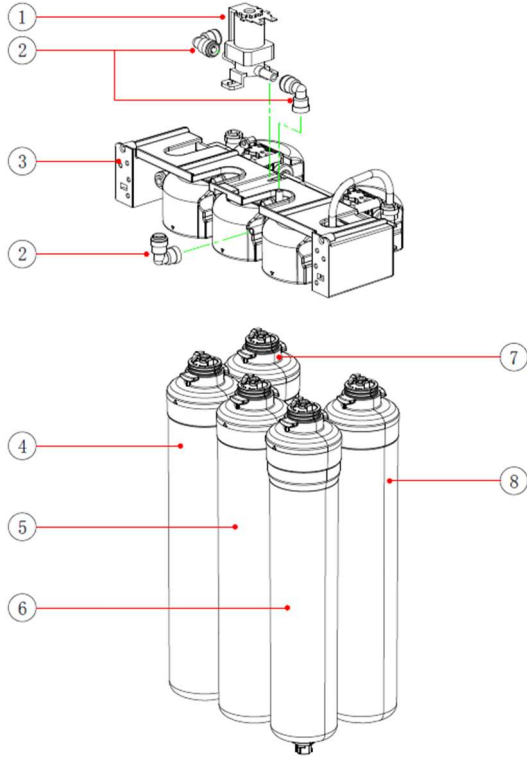

1	EC001A01	S/V High Pressure
3	FL003A01	QC Filter Head Assy
4	WL-QC1	Sediment Filter
5	WL-QC2	Pre-Carbon Filter
6	WL-QC3R	RO(80gpd) Filter
7	WT-QC5	Post Carbon Filter
8	WL-QC4R	Mineral Add-Back Filter

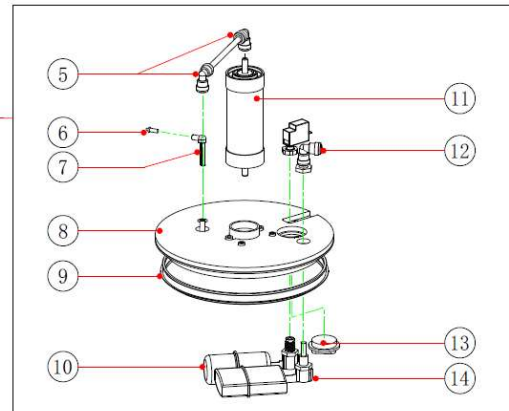
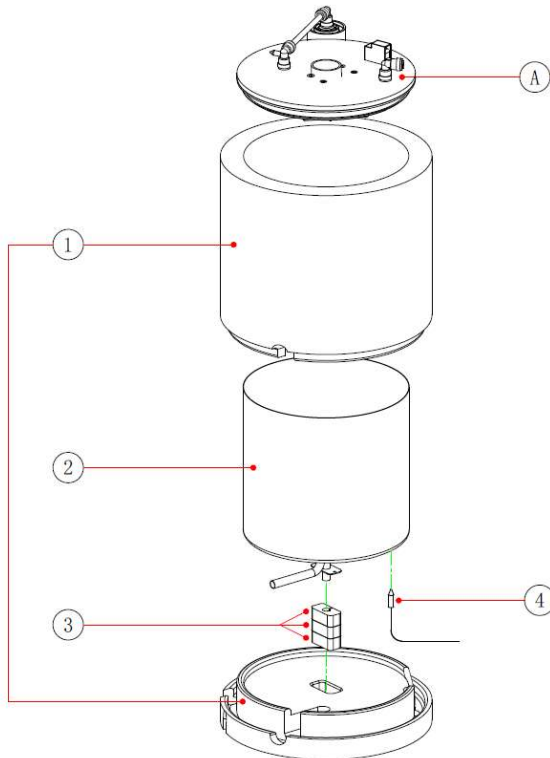

4	EF014A01	Cold Tank Thermostat
8	PG035A01	Cold Tank Lid
10	PF074A01	Micro Float
11	AF	Air Filter
13	EH005A01	UV LED
14	PF073A01	Float

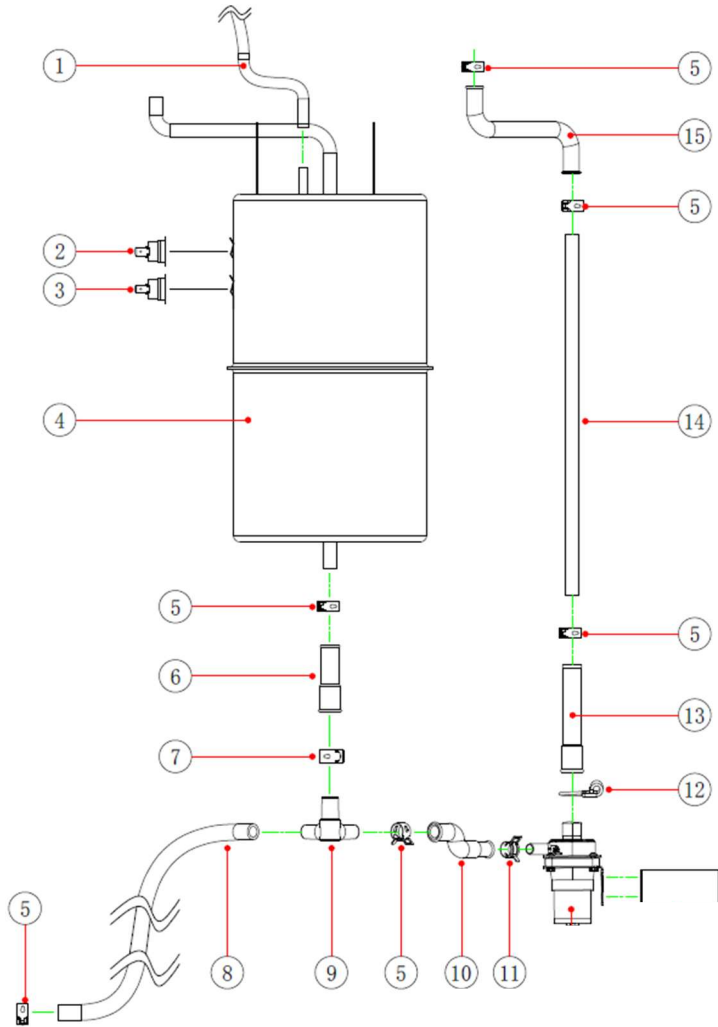

4	TB021A01	Hot Tank
6	RC006K01	Hot Inlet Silicone
8	RB002K01	Drain Hose
10	RC036K01	Pump to Hot Silicone
15	RC039K01	Hot Pump Silicone
17	RC037A01	Cold to Hot Silicone

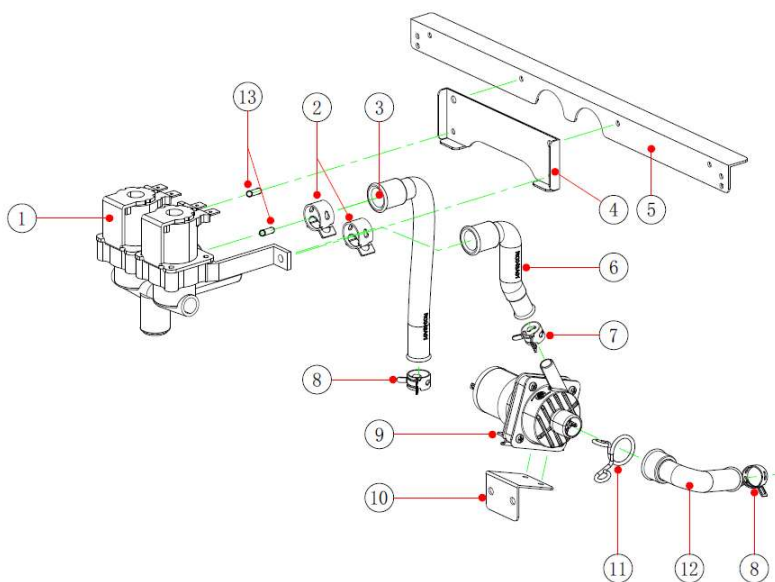

1	EC011A01	Dispense Solenoid
3	RC049K01	Hot Valve Silicone
6	RC048K01	Cold Valve Silicone
9	EE011A01	Cold Water Pump
12	RC033K01	Cold Water Outlet Silicone

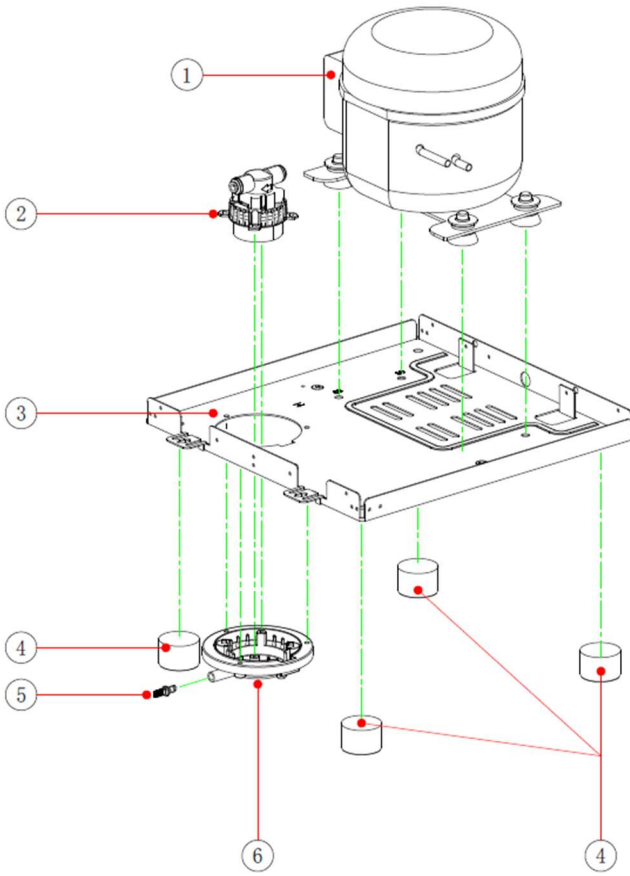

2	11-1546-1	Leak Stop
4	PK113A01	Foot
5	RC043K01	Leak Tray Plug

WL30-RO WATER FLOW DIAGRAM (RO CONFIG)

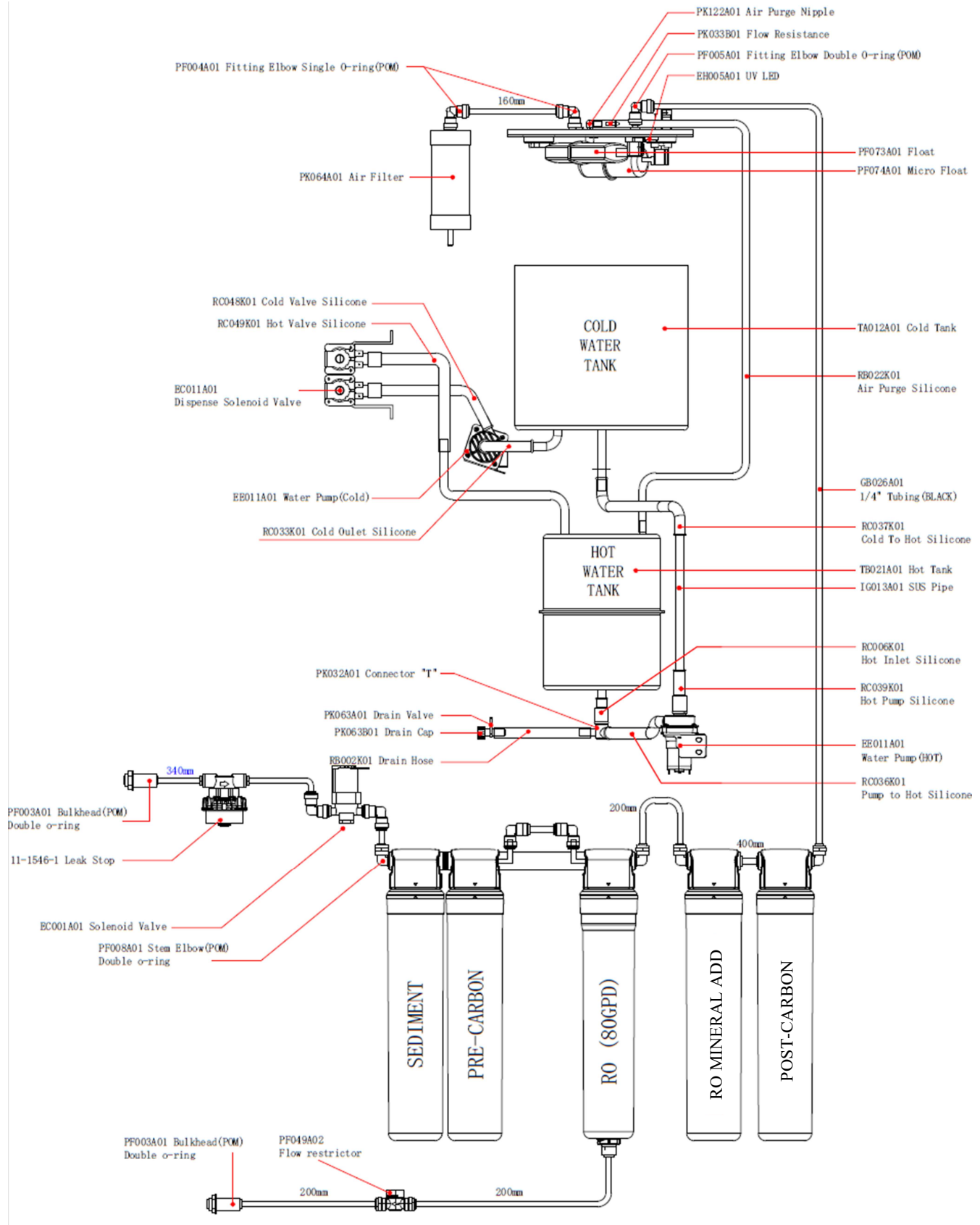

WL30-RO ELECTRICAL DIAGRAM

⚠ DANGER! HIGH VOLTAGE ELECTRICAL HAZARD. PCB (Printed Circuit Board) contains High Voltage. Only trained and qualified technicians should attempt live testing.

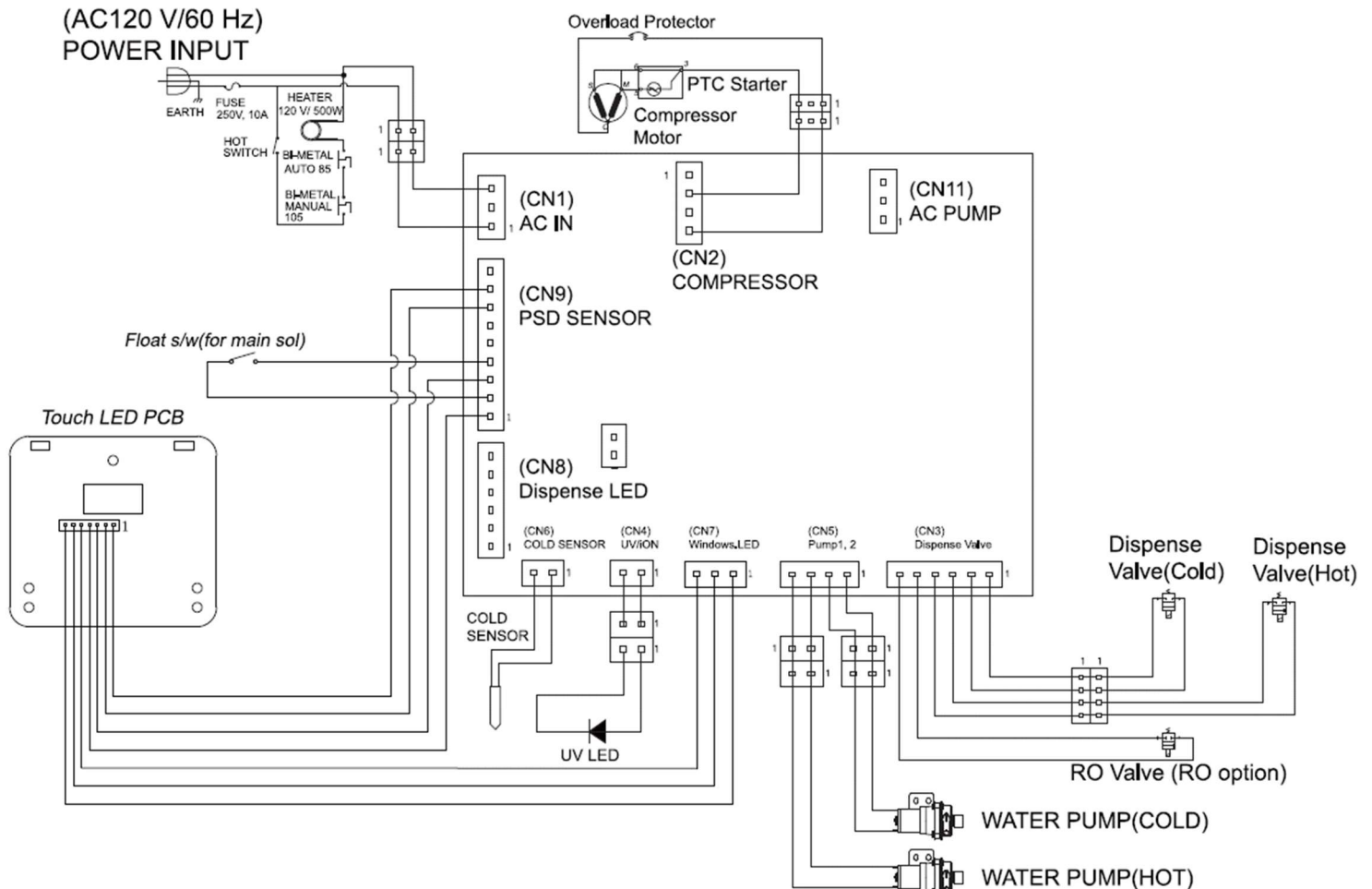

DIPSWITCH SETTINGS

On the PCB of the WL30-RO, there is a set of dipswitches that can be used to control several different settings on the unit. See the chart and photos below for an explanation of the switches. A quick-reference guide is also on the inside of the PCB cover.

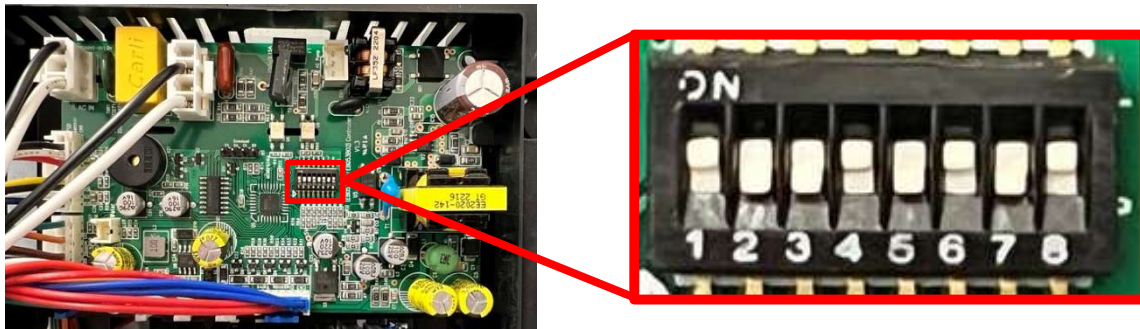

DIP S/W1	FILTRATION
ON	RO
OFF	Micro Filtration
DIP S/W2	FILTER ALARM
ON	FILTER ALARM: ON
OFF	FILTER ALARM: OFF
DIP S/W3	RO/UF FILTER LIFE
ON	24months
OFF	12months
DIP S/W4	STD FILTER CAPACITY
ON	CAPACITY: 1000GAL (3785L)
OFF	CAPACITY: 1500GAL (5678L)
DIP S/W5	COLD TEMPERATURE
ON	ON: 42.8F (6C) / OFF: 39.2F (4C)
OFF	ON: 36.5F (4.5C) / OFF: 34.7F (3.5C)
DIP S/W6	UV
ON	1HR ON / 2HR OFF
OFF	ALWAYS ON (24HR)
DIP S/W7	SPARE
ON	
OFF	
DIP S/W8	MODEL
ON	WL50
OFF	WL30

PRE-INSTALLATION



DANGER! ELECTRICAL SHOCK HAZARD.

*Only qualified personnel who have read and understand this entire manual should attempt to install, or service this **WL30-RO Water Dispenser**, failure to do so could result in death or serious injury. DO NOT plug into an electrical supply until specifically instructed.*



WARNING! ALWAYS SANITIZE BEFORE USE.

Sanitize before use to eliminate any potential microbiological contaminants.

Materials Needed:

- Personal Protective Equipment. Rubber or Nitrile Safety Gloves and Protective Eyewear
 - Phillips Screwdriver
 - Temperature Gauge
 - Water Pitcher or Container to collect water from the faucet
 - 5-gallon container or drain basin
 - Sanitizer - Household Bleach (5.25% Sodium Hypochlorite) or Citric Acid Based Cleaner
 - ¼" Plastic Tubing, at least 10 feet in length, and assorted ¼" quick connect fittings
 - TDS Meter and Test Strips for measuring chlorine – Optional
1. Unpack the **Waterlogic WL30-RO Water Dispenser** and check exterior for damage.



CAUTION! FILTER FLUSH REQUIRED.

WL30-RO Water Dispensers are supplied with filters. The frequency of filter changes depends upon your water quality and your water usage. For example, if there is a lot of sediment and/or particles in your water, then you will have to change your filters more frequently than a location with little to no sediment. Be sure to replace your filters whenever you notice a decline in the performance, whether it is a drop of flow rate and/or pressure or an unusual taste in the water.

2. Flush filters thoroughly per filter manufacturers' recommendation with fresh water to drain. More details are provided in the **Filter Flushing** section further down.

NOTE: Filters should not be flushed prior to 24 hours before installation to limit Microbial Growth inside of filters.

NOTES ON INSTALLATION

1. Do not install the product at the following locations:
 - Near Fires
 - Near Flammables
 - In Humid Places
 - In front of air conditioners
 - Where exposure to rain or snow is possible
 - Outdoors or in direct sunlight
 - Near chemicals (volatile materials, organic solvents, etc.)
 - Near toilets
 - Anywhere the temperature may fall below 50°F.
2. Use source water within following quality range:
 - Water pressure: 50-70psi
 - Water temperature: 39-100°F (4-38°C)
 - Turbidity: 0.5 NTU or less
 - pH: 5.8-8.5
 - Hardness: 300ppm or less
 - Water Quality: Water quality meeting the Drinking Water Quality standard

*Please consult your distributor if source water quality is out of the specified range.

*The warranty will be void if the product is connected to source water that is out of the specified range.

*This product is not equipped with internal filtration. It is intended to be connected only to a potable water source.

3. When transporting the product, do not tilt it more than 45° from vertical.
 - *Severe tilting can cause a performance degradation.
4. Install the product on a flat surface and adjust the level of the unit using a level gauge.
 - *If the product is tilted more than 3°, overflow may occur.
5. Source water should not be above 100°F (38°C)
 - *Hot water may cause performance degradation or system failure.
6. Keep the sides and rear of the unit at least 5 inches (127mm) away from walls or other objects for ventilation.
7. Do not bend the source water or drain hose or place heavy objects on them.
 - *If either are blocked, the water will not flow smoothly to and from the unit, and may cause performance degradation.
8. Do not place any heating system near the rear of the unit.
9. The power supply, source water, and drain must be directly connected to the unit.

FILTER FLUSHING PROCEDURE

Before starting the installation, any filters being used to filter the source water for the unit must be flushed. This is important to rinse any loose carbon or debris from the filters so that it does not plug another filter or membrane or end up inside the unit. [DO NOT install and setup the unit before flushing the filters.](#)

Whether the unit is paired with RO (Reverse Osmosis) or UF (Ultra filtration) filter configurations, there is a basic idea that applies to both: the filters, especially the carbon filters, must be flushed or “rinsed.” This section will cover how to do this process.

Regardless of the setup used, all sediment and carbon filters must have several gallons of water flushed through them to properly rinse the filter. The filters should be flushed in the same direction as flow (with **one** exception).

1. To begin, you will need a ¼” LLDPE tube connecting the unit to a water supply, connected at the “Water In” port on the back of the machine. Install a ¼-turn valve just before the unit to easily turn the water on and off.
2. Have a bucket, pitcher, or sink ready to catch the flush water.
3. Remove the drip tray from the unit by pulling the tray straight out. Once removed, locate the single screw that holds the lower front panel in place and remove it.



4. Remove the lower front panel of the unit. Press down on the top of the lower panel, then pull away. The panel should hinge outward, and then come away from the unit completely. Set this panel aside.



5. This is the view behind the lower front panel. Locate the solenoid on top of the filter bank, behind the PCB housing. Disconnect the tube shown and install a 3-4ft length of tube as a drain line and run to a bucket or sink. Remove the RO filter (twist-tied to the inside of unit). Remove both filters in the back of the filter bank (Post-Carbon and Mineral Add-back filter).

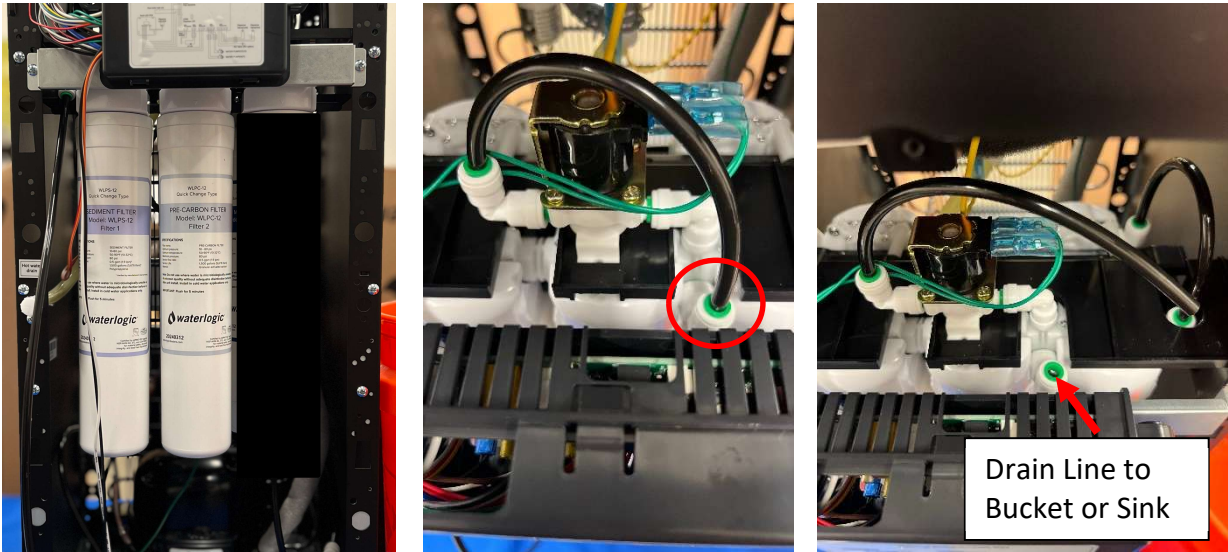

6. With the drain line tubing connected to the out port of the pre-carbon filter ran to a drain or bucket, turn on the water supply and allow 2 gallons of water to flush through the sediment and pre-carbon filters. Shut off the water when complete.
7. Next, remove the pre-carbon filter and install the RO Mineral Filter in its place. Repeat the step above, flushing roughly 2 gallons of water through the mineral filter. Shut off the water when complete. Then, remove both the Sediment and RO Mineral Filter. Install the Sediment Filter into filter head #2, and install the Post-Carbon filter into filter head #1, as shown. Next, remove the supply line from the left port of the filter bank. Replace it with the drain line. Install the supply line into the port the drain line was removed from, as shown.

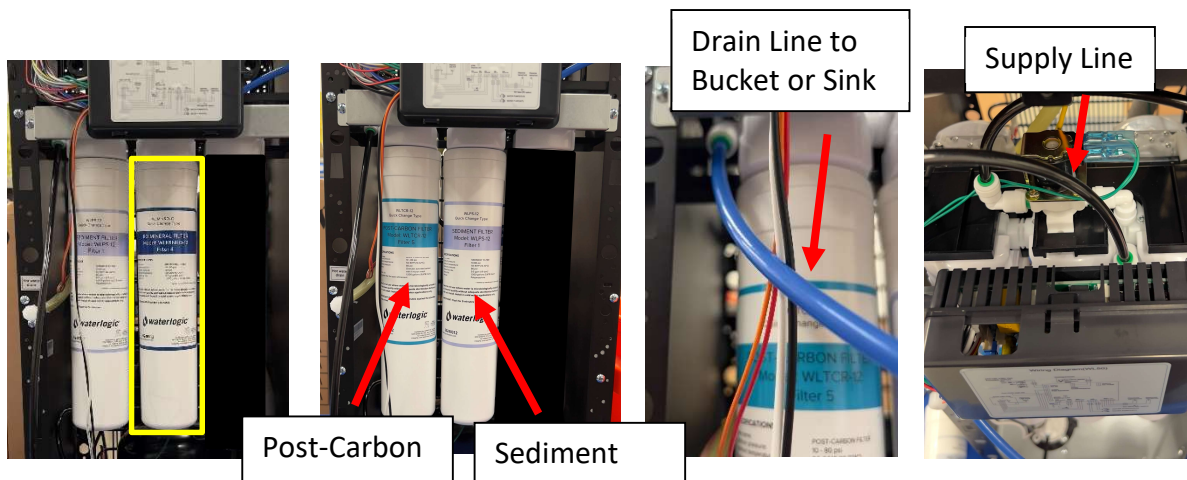

8. Turn the water supply on. This will reverse flush the post-carbon filter. This filter must be reverse flushed because of a mesh screen inside that is susceptible to carbon fines. Once complete, shut off the water supply.
9. With the water supply shut off, return all filters to their original filter heads, and reconnect the black tube of the solenoid valve that was disconnected in step #5. Prepare the RO filter by removing the cap and inlet plug, AND the plug at the bottom in the drain port.



10. Place the RO filter into the third filter head to the right of the pre-carbon filter. Connect the RO drain tube shown. Because the RO filter produces “brine” or reject water in its filtration, ensure the RO Drain port on the back of the machine is plumbed with ¼” LLDPE tubing to a drain or to the same bucket as the flush water.

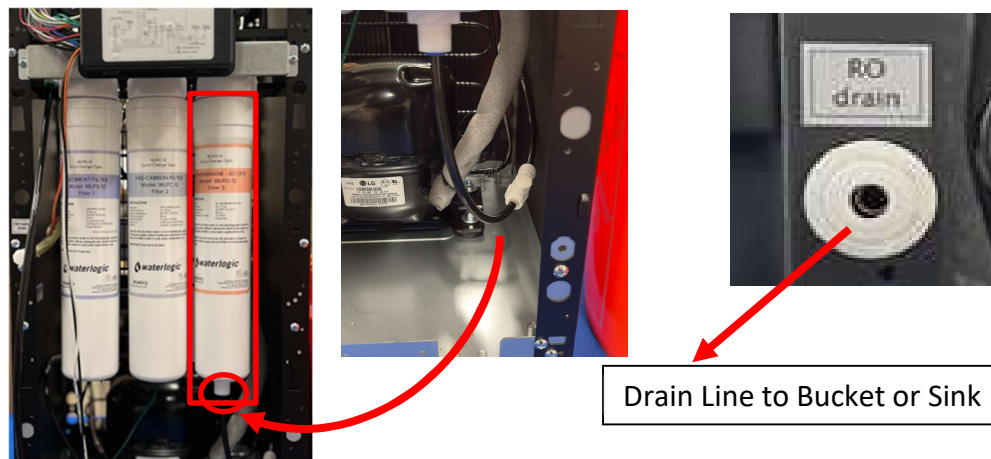

11. Disconnect the black tube shown, coming out of the product port of the membrane, and replace it with the drain line used for flushing.

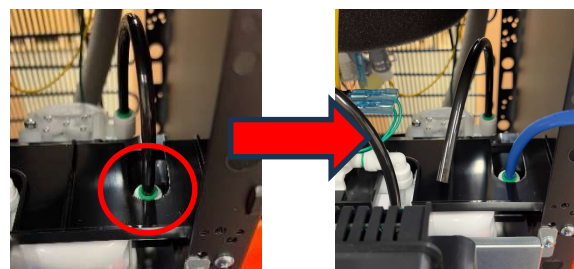

12. Turn the water supply on and allow 2 gallons of water to flush out to drain through the RO filter. This will flush any preservative in the membrane out. Once complete, turn the water supply off. Remove the drain line and restore the connection from the product port of the RO to the inlet of the mineral filter that was disconnected in the previous step.

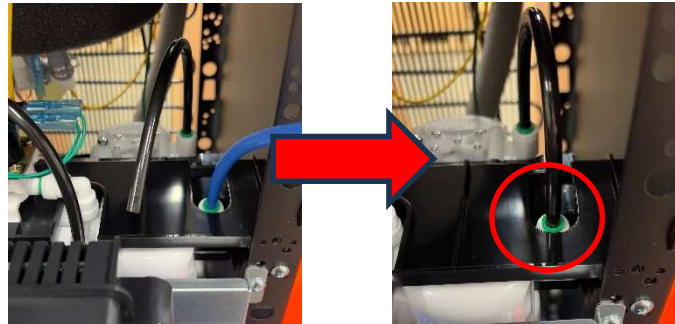

13. The filtration system is now ready to use. The water supply valve can be turned on, and the unit can move forward to the next installation step.

INSTALLATION

Before starting the installation, any filters being used to filter the source water for the unit must be flushed. This is important to rinse any loose carbon or debris from the filters so that it does not plug another filter or membrane or end up inside the unit. [DO NOT install and setup the unit before flushing the filters.](#)

Once the filters have been flushed or “rinsed”, installation can begin. Listed below are the steps to properly install and begin use of the *Waterlogic WL30-RO Water Dispenser*.

1. To begin, you will need a ¼” LLDPE tube connecting the unit to a water supply, connected to the “Water In” port on the back of the machine, and connect the unit to power using the supplied power cable. It is recommended to install a ¼-turn valve just before the unit to easily turn the water on and off. If using an RO filter configuration, the RO Drain port should be connected using the same tubing to a drain connection. Make sure the Hot Tank Power Switch on the back of unit is OFF.

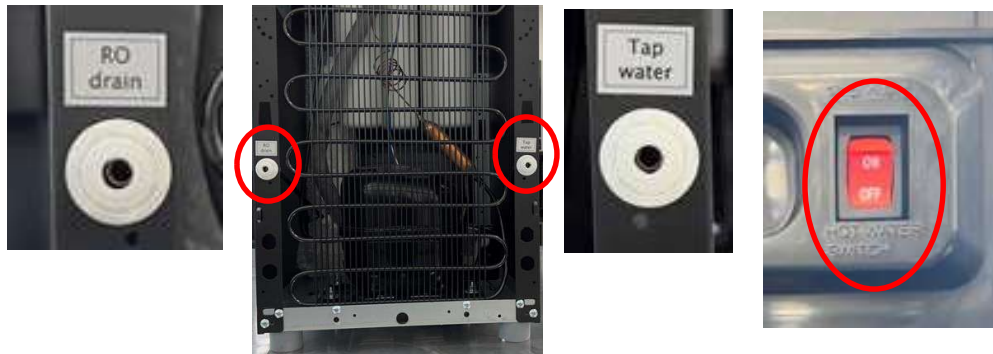

2. If not already done during the filter flushing process, remove the lower front panel of the unit. First, pull the driptray straight out from the unit. Remove and set aside. Locate the screw at the top right of the panel and removed. Then, push the top of the panel down and then pull away from the unit. The panel should hinge outward, and then come away from the unit completely. Set this panel aside. Turn the water to the unit on.

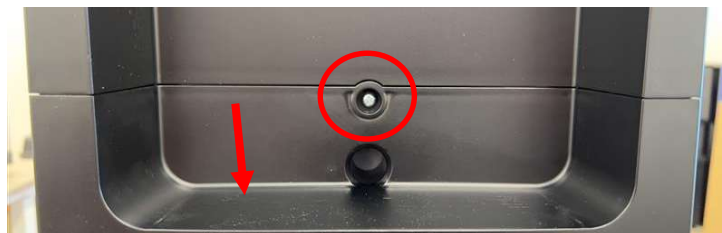

3. Check for any leaks on or around the filters and all connections. Check for any drips or puddles in the bottom of the unit. Ensure the leak stop is dry and in the downward position.

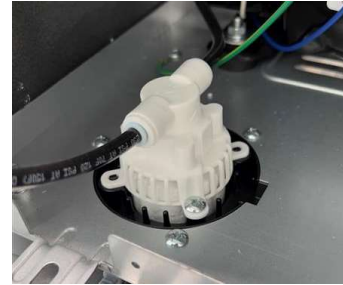

4. Turn the water to the unit on. Water will make its way through the filter system and up to the Cold Tank, and flow downward into the Hot Tank. The Cold Tank will fill halfway first, and then the Hot Tank will begin to fill.

5. Remove the top cover. To do this remove the two screws at the back of the top cover, slide the cover backwards, and lift away from the unit. Shut off the water supply and remove the lid of the Cold tank.

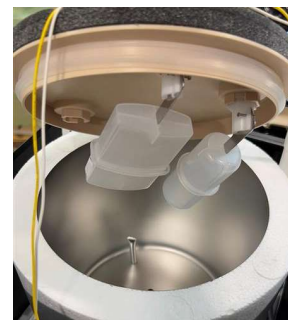

6. Add the recommended amount of an approved sanitizing agent to the water inside the cold tank and gently mix. Allow this mixture to sit in the tank for at least 10 minutes. After 10 minutes has passed, position a bucket or large container under the white drain cap on the right side of the unit, behind the lower front panel. Remove the cap to this drain port and allow the sanitizing agent and water mixture to drain into the bucket. With a pitcher ready, dispense cold water until the tank is empty.



7. Once the tanks have completely drained, cap the drain port, and open the water supply line to allow water to fill the tanks once more. Once full, open drain again and dispense cold water until the tanks are empty. Repeat this step one more time for a total of three flushes.

8. Cap the drain port and turn the water supply on. Place the tank lid back into position and allow the tanks to fill for the fourth and final time. Once the tanks are full, and using the touch sensors on the front panel, dispense both hot and cold water to ensure flow from tanks.

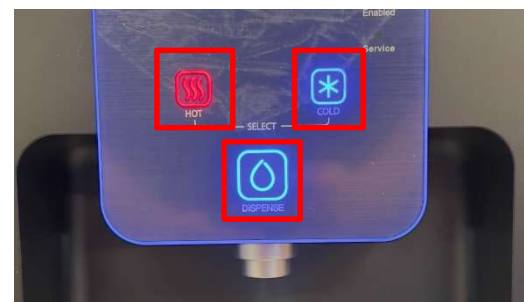

9. Once flow from both tanks is verified, turn ON the switch on the back of the unit labeled “Hot Switch”. This will enable the hot tank functionality and begin heating the water in the hot tank.

10. Return any panels still off the unit to their original positions and reinstall the screws used to hold them in place. The unit is now ready for use. The hot water will need about 15-20 minutes to reach desired temperature, and the cold tank will need about 30-40 minutes to reach desired temperature. Move unit into final position, with at least 3” of clearance from walls on any side facing a wall.



11. Finally, perform a taste test of the water from the cold side. The water should be flavorless with no aftertaste. If any taste is detected, the unit may require more flushing of the tanks.

12. Take a TDS reading of the product water as well. TDS should fall around a 95% rejection rate of the incoming water supply for RO.

$$\left(\frac{\text{TDS Supply} - \text{TDS Product}}{\text{TDS Supply}} \times 100 = \% \text{ Reduction}\right)$$

There is no significant drop in TDS for Micro filtration. If, reduction is significantly less than 95%, the RO filtration system should be inspected for proper function.

WL30-RO PM GUIDE

To ensure proper function and effectiveness of **Waterlogic WL30-RO** units, preventative maintenance must be performed on a timely basis, at a bare minimum of once per year but recommend at least every 3-6 months. PMs typically consist of filter changes but do also require hot tank descaling on a yearly basis, especially if not using RO filtration. The filter change schedule is listed below. **DO NOT run the filtration system in the unit before flushing the filters.**

PART NUMBER	FILTER TYPE	FILTER CHANGE FREQUENCY
WLPS-12	SEDIMENT FILTER	6-12 Months
WTCR-12	POST-CARBON FILTER (TCR)	6-12 Months
WLRO-12	RO MEMBRANE	Test TDS reduction at 12 months
WLPC-12	PRE-CARBON FILTER	1,500 Gallons
WLMINRO-12	MINERAL FILTER (RO)	6-12 Months
AF	AIR FILTER	3 Years

It is imperative to regularly change the filters on the Waterlogic WL30-RO unit. Changing the filters keeps the tanks clean and the water tasting fresh. Failing to change filters regularly can also cause premature degradation of RO filters, which can increase maintenance costs. [Refer to the filter flushing guide for the proper flushing procedure.](#)

Regularly sanitizing the cold tank and descaling the hot tank will also help to improve the water quality and prevent costly maintenance (or even replacement) of the hot tank. The sanitizing and descaling procedures are outlined below.

Sanitizing and Descaling

Sanitizing both the cold and hot tanks will help to prevent buildup of Bio-film and will ensure the best water quality and taste. **The procedure for sanitizing is the same for descaling**, the only difference being the solution used, either a **sanitizing agent** or a **descaling solution**. The sanitizing and descaling procedure is outlined below.

1. The unit should already be hooked up to a water supply and power supply and recently had new filters flushed and installed. Ensure the hot tank switch on the back of the unit is turned OFF. If these prerequisites are met, proceed.



- Remove the drip tray from the unit by pulling straight out. Once removed, locate the single screw that holds the lower front panel in place and remove it. Then, press down on the top of the panel and pull outward. The panel should hinge outward and then come away from the unit completely. Set this panel aside.

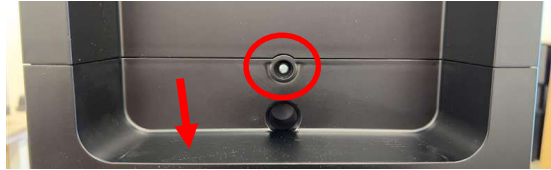

- Remove the top cover. To do this remove the two screws at the back of the top cover, slide the cover backwards, and lift away from the unit. Shut off the water supply and remove the lid of the Cold tank.



- Add the recommended amount of an approved sanitizing agent OR descaling solution (but not both) to the water inside the cold tank and gently mix. Allow this mixture to sit in the tank for at least 10 minutes. After 10 minutes have passed, position a bucket or large container under the white drain cap on the left side of the unit, behind the lower front panel. Remove the cap to this drain port and allow the solution to drain into the bucket. With a pitcher ready, dispense cold water until the tank is empty.



- Once the tanks have completely drained, cap the drain port, and open the water supply line to allow water to fill the tanks once more. Once full, open drain again and dispense cold water until the tanks are empty. Repeat this step one more time for a total of three flushes.

- Cap the drain port and turn the water supply on. Place the tank lid back into position and allow the tanks to fill for the fourth and final time. Once the tanks are full, and using the touch sensors on the front panel, dispense both hot and cold water to ensure flow from tanks.



- Turn the hot tank switch on the back of the unit to ON. Return the front lower panel and top panel to the unit and reinstall all fasteners. The unit is now ready for use, and the hot water will be up to temp within 15min.



RESETTING THE HOT TANK OVERLOAD THERMOSTAT

In the event of a “dry heat” scenario during installation, or if the water supply is blocked to the hot tank, overload thermostats are installed on the Hot Tank to prevent an unsafe heating situation and prevent damage to the unit. If these thermostats sense heat that is too high, they will trip and break the power circuit to the heating element. When this happens, the Overload Thermostat must be manually reset.

CAUTION!: Disconnect the machine from its power source before attempting the next steps. Failure to do so could cause electrical shock.

To do this, remove the upper front panel of the unit and locate the hot tank. On the surface of the hot tank, where a section of insulation is cut away, the overload thermostat is mounted to the metal round of the tank. There is a small red/pink button in the center of the thermostat that must be pressed to reset the thermostat. Doing so will restore a continuous path for power to reach the heating element. Before doing so, ensure that water dispenses from the unit during the hot water dispense operation. If water flows from the hot tank, the tank is primed and full of water. Disconnect power and continue with resetting the thermostat. Once done, restore power and the water will begin heating, and hot water should be available within 5-10 minutes.

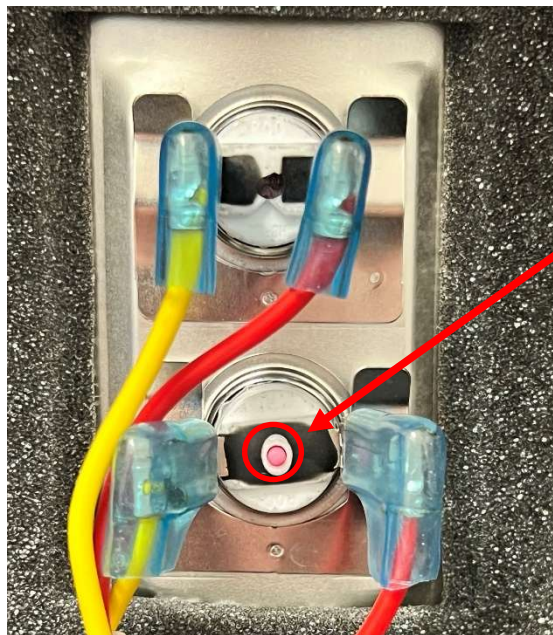

FINAL INSPECTION

After installation and sanitization, verify the following:

1. There are no leaks or loose components.
2. The hot water is over 160°F.
3. The cold water is below 50°F.
4. Confirm acceptable product water flow.
5. If the system is not filling, then check the water supply and also make sure the leak stop has not been tripped. ***The leak stop can be reset by removing the cap below the unit and draining the water out.**
6. Ensure the systems exterior is clean and all components are in place.

Other items to check:

1. Once the system has been flushed it should remain plugged in and water should, at a minimum, be dispensed occasionally. ***Avoid storing in your vehicle or warehouse with residual water in the tank, this will result in a bad taste after installation.**
2. Always drain the system before moving it. It is not necessary to drain the hot tank completely if installing the same day. Leaving water in the hot tank will allow you to turn the hot tank on immediately after installation of the system but if left overnight may result in a taste complaint.
3. Never lay the system on its side.

PREVENTATIVE MAINTENANCE

The following is an outline of preventative maintenance that should be performed on yearly or semi-yearly basis to keep the unit running in top shape.

1. Change filters according to the filter change schedule. Always rinse new filters using the same procedure as the original filters.
2. Drain the system and use an approved cleaning agent to sanitize the system as outlined in the sanitization section.
3. Check all fittings for signs of scale or wear and replace as needed.
4. Check solenoids for proper function. Dripping solenoids should be replaced immediately.

Every 5 years, in addition to the above, perform the following:

- Replace all internal fittings and tubing.
- Replace solenoids.

SYSTEM INSPECTION

When changing filters or performing service, the following items should be completed:

- Visual Inspection
- Hose & Fitting Inspection
- Electrical Inspection
- Pressure and Flow Test
- Clean the exterior of system and condenser coils on rear of system.
- Temperature Check (Cold water should be below 50°F, Hot water should be above 160°F)
- TDS Check
- Hot Tank Switch On
- Site Cleanup

WARRANTY PROCEDURE

Procedure for WL30-RO warranty evaluation:

Contact WATERLOGIC technical support and provide the following information:

- Serial number
- Failure
- Full details around failure
- Water pressure into the system
- Tap TDS
- TDS out of the cold and hot tanks
- Pictures

Depending on the situation, technical support may request more information. Upon approval, WATERLOGIC will process warranty credit or replacement part to be fulfilled

TROUBLESHOOTING INDEX

1. No Power, Panel not Lit.
2. Cold Water is not Cold
3. Hot Water is not Hot
4. No or Low Flow of Water
5. Overfill of Cold Tank
6. Operation Sensors are Unresponsive
7. Leak Stop Triggered
8. Filtration

1. No Power, Panel not Lit

Possible Reason	Solution
Power Cord Disconnected	Ensure the power cable is properly plugged into the wall power outlet.
Tripped GFCI	Reset GFCI outlet.
Blown Fuse	Check Fuse at the rear of unit where the power cable connects.

2. Cold Water is not Cold

Possible Reason	Solution
Cold Thermistor Fault	Replace Cold Thermistor.
Compressor Failure	Check temperature of compressor and report your readings to technical support.

3. Hot Water is not Hot

Possible Reason	Solution
Hot Tank Thermostat Failure	Hot Tank Thermostat has tripped and will need to be reset.
Hot Switch is Off	Switch on back of machine has been switched off. Switch it On.

4. No or Low Flow of Water

Possible Reason	Solution
Source Water Turned Off	Make sure the source water feed is turned on.
Clogged Filter	Check flow individually from each filter to ensure flow. Replace any filter with reduced flow.
Solenoid Clog or Failure	Check dispense solenoids for proper function. May need to be disassembled to remove blockage, or replaced if failed.

5. Overfill of Cold Tank

Possible Reason	Solution
Mechanical Float Failure	Check function of fill float on underside of tank lid. When the float lifts, it should choke water flow to zero. If not, replace.

6. Operation Sensors are Unresponsive

Possible Reason	Solution
Power Failure	Check power at outlet, and check fuse on the back of unit.
Sensor Failure	Ensure sensor has not disconnected from PCB. Ensure front panel protective film has been removed from the unit. If sensor is still unresponsive, replace them.

7. Leak Stop Triggered

If water leaks into the bottom tray of the unit, the leak stop will be tripped and the water supply to the filters will be cut off.

To correct this, any leaks must be found and properly repaired/corrected. Then, any water in the bottom tray must be dried up. Then, the leak stop underneath the filters must be reset. **Ensure** that there is no moisture in the bottom of the unit.

8. Filtration

It is recommended using RO where possible and almost always if TDS from the tap is greater than 150 PPM. For an RO to work properly it is very important that the following variables are addressed and performed properly.

- Incoming Water Pressure: RO's require 60-70psi to work properly.
- Lower PSI will cause the reduction in TDS to suffer greatly, as well as the recovery rate.
 - 60psi results in (roughly) 7.3oz/min from 80GPD membrane.
 - 40psi results in (roughly) 2-3oz/min from 80GPD membrane.
 - 60psi results in (roughly) 98% reduction of TDS from the RO
 - 40psi results in (roughly) 80-85% reduction of TDS from the RO
 - Example:
 - 500 Tap TDS at 98% reduction = 10TDS product water
 - 500 Tap TDS at 85% reduction = 75TDS product water
 - 500 Tap TDS at 80% reduction = 100TDS product water
 - With the mineral add back filter a high concentration of calcium will negatively impact the amount of scale that will, as a result, negatively impact ice systems.
 - When using a bladder, this is much more susceptible to manifesting itself as a problem.
 - As the bladder pressure pushes back on the filter, lower pressure will reduce recovery even beyond the above stated levels and will be unable to properly fill the bladder.

- This will also result in burning through pre filters as it will take much more water to make little product water.
- Signs of this issue in gravity fed tanks will be manifested mostly through form of taste complaints, in this system it will manifest itself as running out of water prematurely.

Solutions for Low Water Pressure:

- Add a Booster Pump
- Use Micro Filtration (be sure to remove the mineral add back filter)

Bladder Tanks:

- It is important that the right size bladder tank be used in conjunction with sufficient flow.
- It is ALSO important that the bladder tank be set to the correct pressure.

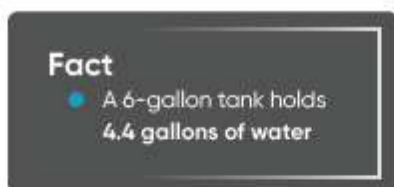

- Increasing air pressure will reduce the water capacity while also increasing water pressure
- Decreasing air pressure will increase the water capacity while also decreasing water pressure
- With no air the water tank will be full, but there will be no pressure to release water



Bladder Tank Water Pressure Changes

Bladder tanks have fluctuating water pressure as they empty. This may impact the flow rate going to the system as the tank is depleted.

- The amount of bladder tanks, filter banks feeding the bladder, pressure, and if a booster pump are needed must all be considered for install requirements. No two accounts are the same and usage will greatly impact the decision. If you have a large bladder tank installed and you have reports of no water, please revert to the above section on how to check to see if water flow is an issue.
- For large usage account with larger bladders, it may be necessary to have additional filter banks to improve the recovery time.
 - Please note that when doing this a booster pump may become necessary even if there a tap pressure of 60psi.
 - Failure to take this into consideration may cause the bladder to ineffectively fill due to pressure drop with multiple units in line which mainly manifests itself as the larger bladder tanks get closer to filling

- This will also result in burning through pre filters and using a lot of water that will ultimately be just sent down the drain

Please see below for recommended air pressure that should be in the bladder depending on size of the bladder.

Size	Part Number	Size	Recommended Air Pressure
4 Gallon	EQGENE-0004	11" (Diam.) x 14" (Height)	6-7 psi
14 Gallon	EQGENE-0014	15" (Diam.) x 23" (Height)	6-7 psi
20 Gallon	EQGENE-0020	16" (Diam.) x 29" (Height)	7-10 psi
32 Gallon	EQGENE-0032	21" (Diam.) x 28" (Height)	7-10 psi
44 Gallon	EQGENE-0044	21" (Diam.) x 37" (Height)	10-15 psi
85 Gallon	EQGENE-0085	26" (Diam.) x 45" (Height)	10-15 psi
120 Gallons	EQGENE-0120	26" (Diam.) x 60" (Height)	10-15 psi