

S18 Undercounter Chiller

Product Manual

Filtered Undercounter Cooler
Carbonator

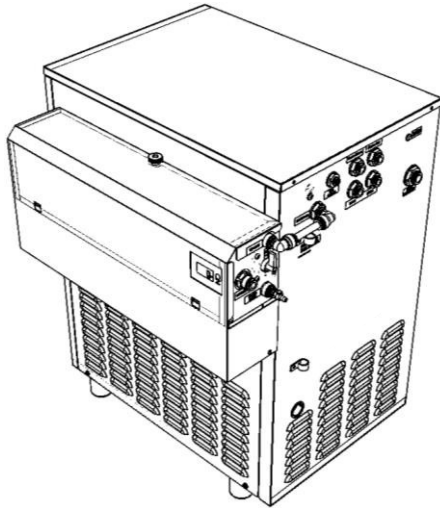

4B0004



Technical Support
witechsupport@quenchwater.com
(800) 288-1891

Introduction and Specification

Contents

Section	Page	Section	Page
Introduction, Specification	2	Fault Finding	11-12
Installation & Commissioning	3-6	Spare Parts	13-14
Schematics	7	Removal, Transportation and Disposal	15
Cleaning	8-10		

Introduction

The S18 UC is a high capacity cooler carbonator. The unit is designed to deliver a choice of filtered chilled and ambient still water and chilled carbonated water.

The unit should be isolated from the electricity supply before removal of any covers. Great care must be employed when working with high pressure carbon dioxide, and in no cases should the maximum operating pressure of 4bar be exceeded. The over counter unit uses R290 (Care 40, Propane) refrigerant. Below are some safety warnings which the end user must adopt to mitigate the risk of unsafe conditions arising.

Specification

Dimensions	D – 19.6" (500 mm) W – 13.8" (350 mm) W – 17.8" (454 mm over filters) H – 25.2" (640 mm)	Compressor	Huayi NUY70NRa
		This product contains fluorinated greenhouse gas with a GWP of 1300 in a hermetically sealed system.	
Supply	115 Vac 60Hz	Refrigerant	R290, 1.8oz (50g)
Rated Input	920 W	Climatic Class	N
Rated Current	8A	Potable water inlet pressure	40 psi (2.76 bar) min 60 psi (4.14 bar) max
CO2 Pressure	55 psi (3.8 bar)	Nominal ice bank	24 lbs (11 kg)

Installation and Commissioning

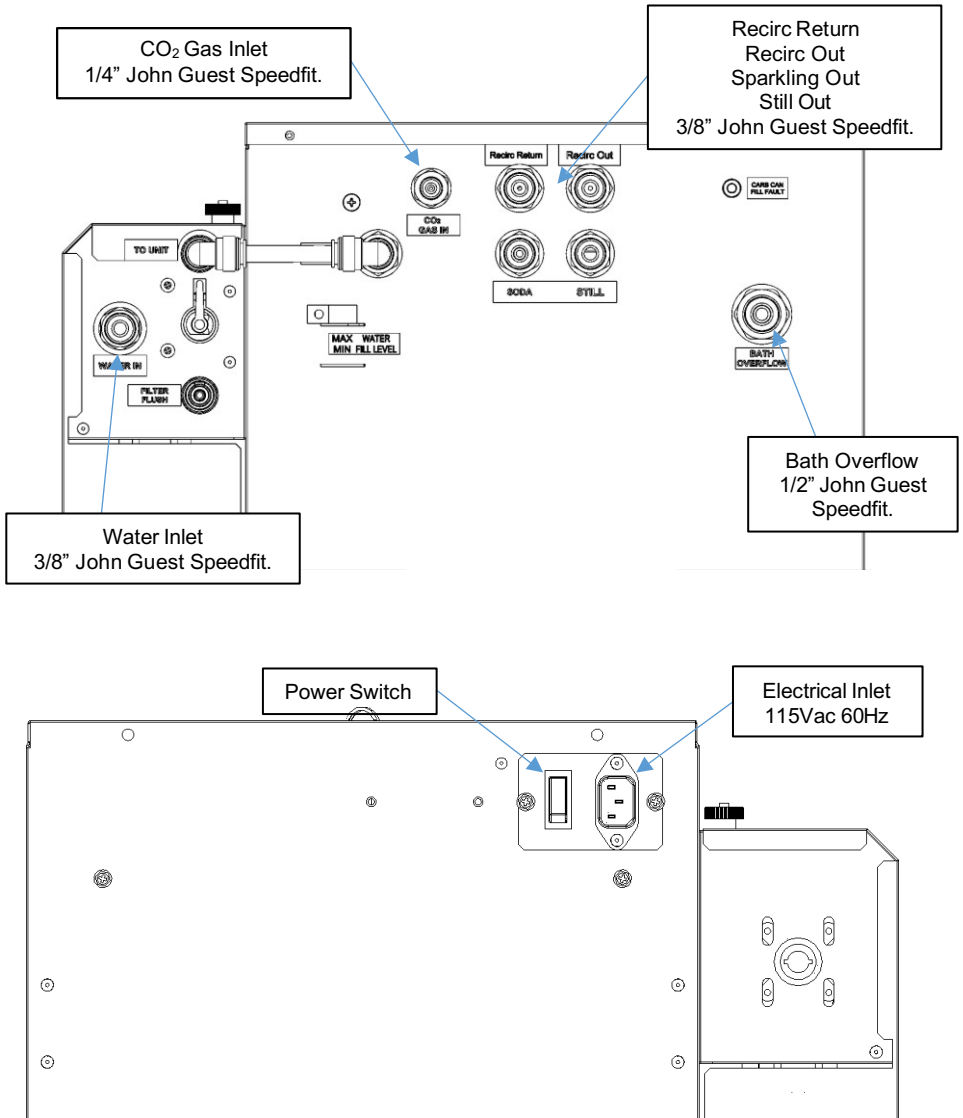

Installation and Commissioning

- The unit must be installed by a competent person, on a firm level surface capable of supporting the weight of the machine, when the bath is filled.
- Make all connections for water (inlet and outlet), gas and electricity, but do not turn these on at this stage.
 - If the recirculation system for this unit is not being utilised the Outlet and Return can be linked by a length of insulated John Guest tubing.
- Important: Ventilation openings in the machine must not be blocked and free movement of air through the unit must be possible. Inadequate ventilation will shorten the life of the fridge system. Air is drawn in through the front, sides and bottom of the unit and exhausted to the rear.
- Ensure that the supplied base guard is fitted to the underside of the unit.
- Fill the bath with water. To do this remove the lid from the unit and remove the bath inspection cover. Min and Max water levels are marked on the front of the unit.
 - If the recirculation system is being utilized, then the bath water will need to be monitored and topped up accordingly as the recirculation tubing fills up. This will occur during first power on.
- Remove the cover from the filter housing and fit all water filters into the housing. The filters are a twist and lock design and will lock into place after a ¼ turn (a clicking sound will be heard, and the red release tab will spring into its locked position).
- Turn on the CO₂ gas supply, ensuring the pressure is set to 55 psi (3.8 Bar).
- Purge the carbonator can by pulling the ring pull of the pressure relief valve on top of the can and let gas flow for up to 5 seconds then close.

Installation and Commissioning

- Before turning on the water supply locate the flush valve at the front of the filter housing and turn the lever to the 'Flush Position'. Connect the clear PVC tubing supplied to the flush outlet and place the other end of the tubing into an empty bucket or to a drain.
- Turn on the water supply. Water will now begin to flow through the water filters and the flowmeter will display a flow rate. When the filters are full, water will flow out of the clear tubing. Initially the water will contain some sediment from the carbon filtration, this is normal, allow to flow until clear.
- Once clear, turn the flush valve lever back through 180° into the 'Unit Supply Position'. Water will now be directed into the water circuit of the unit.
- Open the still tap until water flows (this may take a few seconds as the cooling coil inside the unit fills with water) then close. At this stage re-fit the lid and filter housing cover.
- Turn on the electrical supply. After a short delay the fridge system will activate (check for air exhausting to the rear of the machine) and the carbonator can fill pump will activate; once the can is filled the pump will automatically switch off.
- To ensure all air is purged from the carbonator can, turn off the electrical supply and dispense sparkling water until the can is empty, then allow gas to flow from the dispense tap for 5 secs.
- Restore the electrical supply. The fridge system and can fill pump will activate as before and the can pump will switch off when the can is full. When the compressor and fans switch off the unit is ready.
- Depending on the ambient temperature and the temperature of the incoming water the time required for the fridge system to switch off can take 3 to 5 hours. In very high ambient conditions (90°F/32°C or higher) the time required may be over 5 hours.
- Note: If the bath has been filled to the point of overflow, approximately 17 fl oz (0.5 liters) of water will be displaced as ice forms in the bath.

Installation and Commissioning

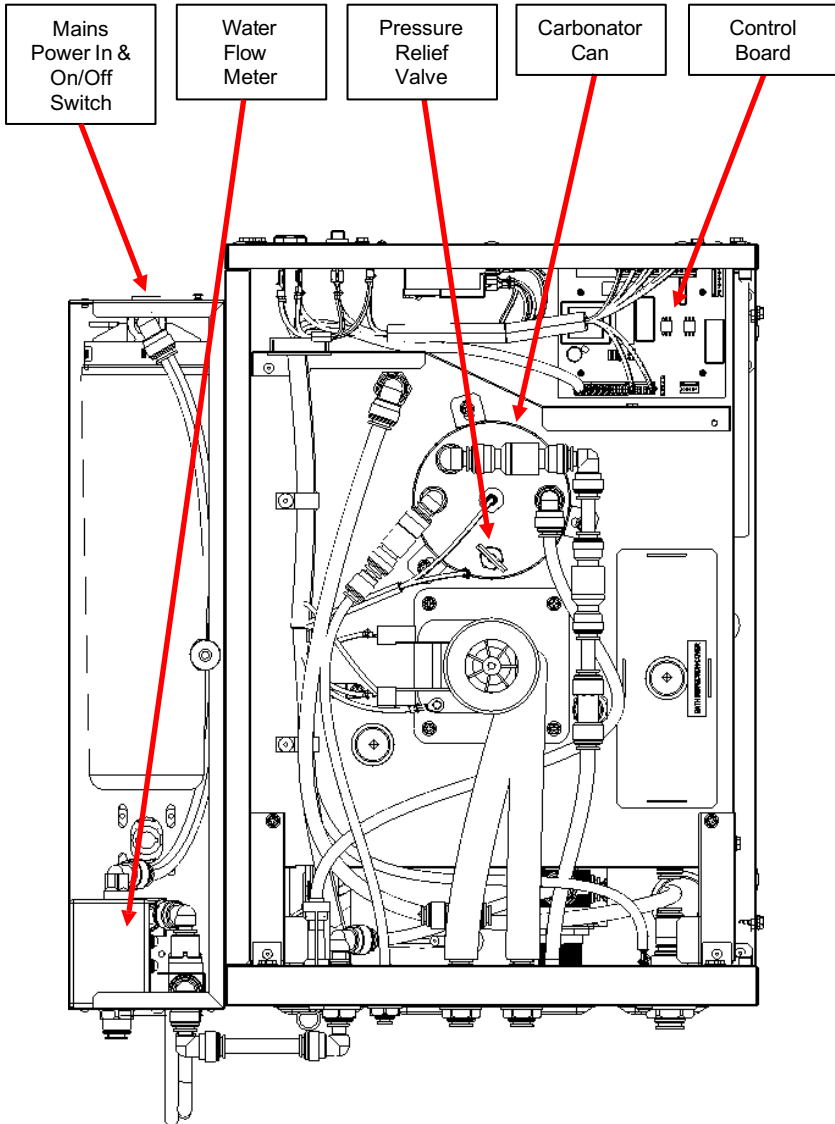

Schematics

Electrical Circuit

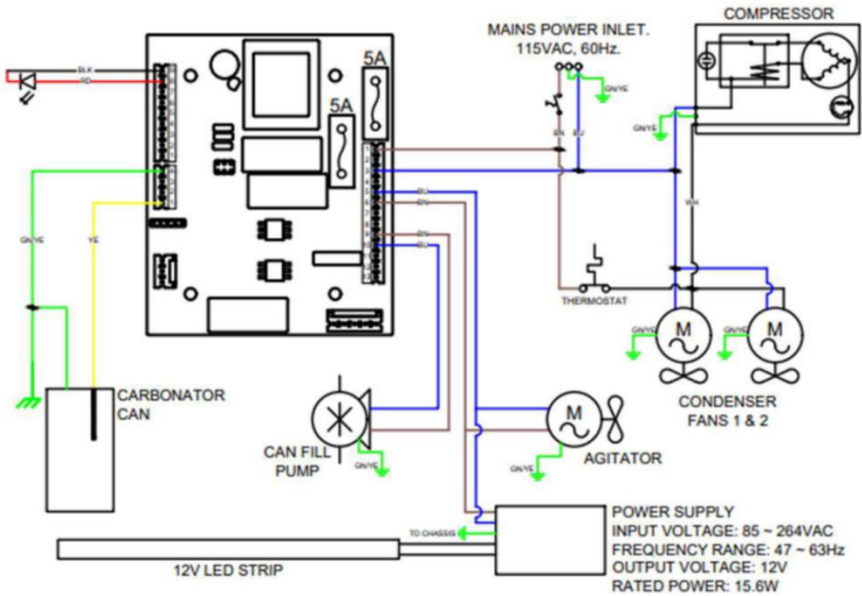

Water Circuit

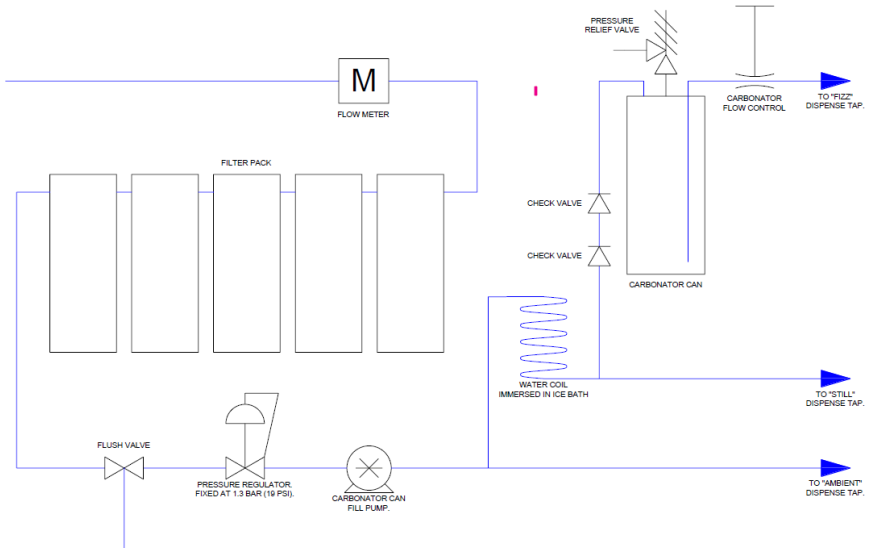

Cleaning

Important:

The frequency of the following cleaning procedures should be determined locally and may vary depending on machine usage and environmental conditions.

- Warm water should be no higher than 113°F.
- After any cleaning procedure, dispense a minimum of 34 fl oz of water from all taps to ensure any cleaning residue is flushed out.

Routine Clean - Use the appropriate methods below.

Important: It is recommended that the routine cleaning procedure be performed at least weekly.

Multi-Purpose Disposable Cloth.

Use the cloth to apply the cleaning agent. Submerge a clean cloth into the cleaning agent (concentration recommended by manufacturer's instructions). Remove the cloth and remove excess water. Clean the dispense components by wiping the cloth over the entire area re-submerging the cloth as necessary. Rinse the cloth in clean warm water and wipe off excess cleaning agent residue and soil. Dry using disposable paper towels, replace dispense components.

Spraying on Cleaning Agent.

Remove all dispense components. Liberally spray the cleaning agent at the concentration recommended by the manufacturer onto the dispense component ensuring that the whole area has been covered. Finish the cleaning by exchanging the cleaning agent for warm water, remove the soil with a multi-purpose disposable cleaning cloth and dry the component with disposable paper towels.

Food Grade Antibacterial Wipe.

Remove the dispense components, wipe the dispense component with the food grade antibacterial wipe, remove all visible soil. Replace dispense component.

Cleaning

Deep Clean - Parts in contact with food products

Important: It is recommended that the deep clean procedure be performed at least monthly.

Remove dispense components, pre clean using a damp multi-purpose disposable cleaning cloth soaked in warm water.

Soak cloth in cleaning agent solution, remove excess water and clean dispense components. Using a brush, brush dispense head to dislodge any dried-on soil. Remove soil with the cloth.

Rinse dispense nozzles with a new multi-purpose disposable cleaning cloth soaked in warm water until all soil and cleaning agent residues have been removed.

Soak multi-purpose disposable cleaning cloth in disinfectant solution, apply to dispense component, ensure that the whole area is wiped. Leave for 10 minutes. Rinse off disinfectant using multi-purpose disposable cleaning cloth that has been soaked in clean warm water. Dry dispense component with disposable paper towels. Refit all dispense components.

General Cleaning - Parts not in contact with food products

Important: It is recommended that the procedure should be performed at least every 6 months.

Condenser. At regular intervals, determined by local environmental conditions, the condenser should be thoroughly cleaned with a small stiff brush and/or a vacuum cleaner. Do not use screwdrivers or other sharp implements which may puncture the tubes and damage the fins.

Warning: Failure to clean the condenser can shorten the life of the compressor causing premature failure of the unit.

Outer Panels. Clean the outside panels, pay particular attention to the edges of the panels where spillage could have ingressed and the area around the base of the unit. If necessary, remove the unit and thoroughly clean around the base and floor.

Sanitization

Important: It is recommended that the procedure is performed during initial installation and at least every 3 months.

Cleaning

Prepare the Unit

1. Disconnect the electrical power to the unit and isolate from the water supply.
2. Carefully following the manufacturer's instructions, prepare a solution of proprietary sanitizing fluid.

Sanitize the Water System

3. Disconnect flexible water inlet tube from the water supply and place the end into a container of sanitizing fluid. Flushing through of sanitising solution can be achieved either using a pressurised container, or by using a syphon. In the latter case, the sanitiser fluid needs to be held at a height sufficient to allow fluid to flow through the chiller. Flush through approximately 17 fl oz of water to flood the chiller with sanitizing solution
3. Leave to stand for period recommended by sanitizer manufacturer
4. Follow Routine Clean procedure to clean dispense pipework.

Recommission the Unit

5. Restore the water supply to the unit and dispense a minimum of 34 fl oz of water to flush the system of sanitizer.
6. Restore the electrical supply and allow the unit to complete its cooling cycle.

Fault Finding

Prior to any fault finding, please ensure all water and gas connections to the chiller are sound and that the incoming water and gas supplies are turned on. Also ensure that all electrical connections to the chiller and in the chiller are secure and in good condition, the power is on.

If the above are satisfied, ensure that the chiller has had adequate time to reach operating temperature.

A status LED is located on the top rear panel and indications are:

Status	LED
Normal operation	OFF
Water pump timeout	ON 1 second - OFF 2 second

Timeout and protection events can be reset by cycling mains power off then on. The cause of the event should be investigated and corrected.

Symptom	Possible Cause	Corrective Action
No Water Dispensing	Inlet valve not open.	Check water supply is connected and on.
		Check internal isolation valve is open.
	Ice bath frozen up.	Check thermostat probe is fully inserted into the bath.
		Check for ice bath contamination, melt ice, drain bath and refill. If contaminated, identify & rectify source of contamination.
		Check that the thermostat is functioning correctly. Replace if necessary.
	Water pressure regulator	Check water can flow through the regulator. Replace if necessary.

Fault Finding

No Carbonated Water	CO2 pressure (check by operating pressure relief valve on carbonator can)	Check CO2 bottle, regulator and non-return valve. Supply pressure should be 55 psi, adjust or replace as necessary.
	Carbonator Can Not Filling	Check carbonator probe for possible short circuit to ground. Including moisture on the can lid.
		Check LED for pump timeout indication. If timed out, cycle power off & on then purge carbonator.
		Check supply to water pump (115V AC), if voltage present & pump inoperative - replace pump.
		If voltage not present & pump is not timed out, check PCB fuses. If necessary, replace PCB
Poor Quality Carbonation	Incorrect CO2 Pressure	Check CO2 bottle, regulator and non-return valve. Supply pressure should be 55 psi, adjust or replace as necessary.
	Air in Carbonator Can	Purge the carbonator can by operating the flush switch until empty and CO2 is dispensed for 5 seconds.
	Residue in Carbonator Can	After prolonged use, a surface film can develop within the carbonator can preventing good carbonation. This can be removed by flushing the system using a solution of citric acid, refer to cleaning and sanitising instructions.
	Carbonator can is overfilled	If pump runs continuously, check connections to can level probe, if problem persists replace the PCB.
Warm Drinks	Compressor not running	Possible overheat. Allow unit to cool. The compressor will start once the unit has cooled sufficiently. If the problem persists investigate possible causes.
	Insufficient air flow through the fridge.	Check that the condenser is not blocked.
		Check that the air filter is not blocked
		Check the cooling fans are running.
Fridge failure	If compressor & fans are running and there is no cooling, return for repair.	

Spare Parts

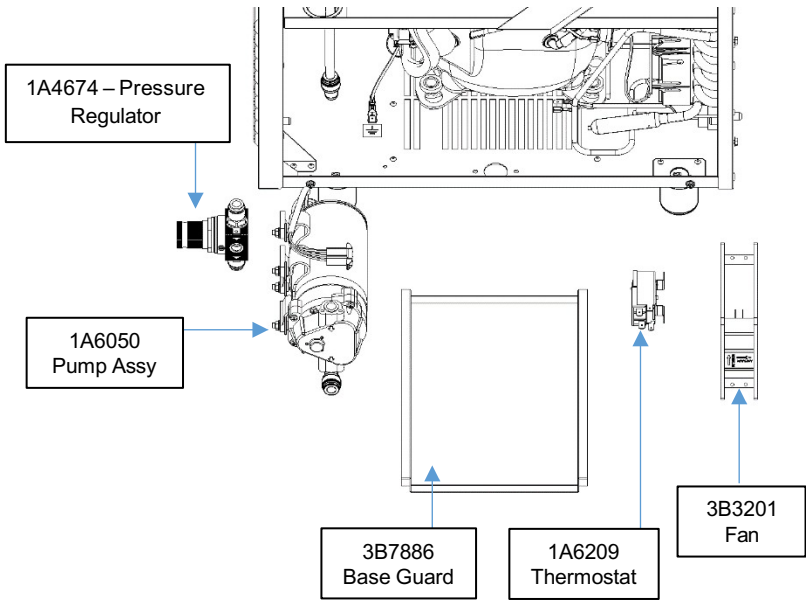
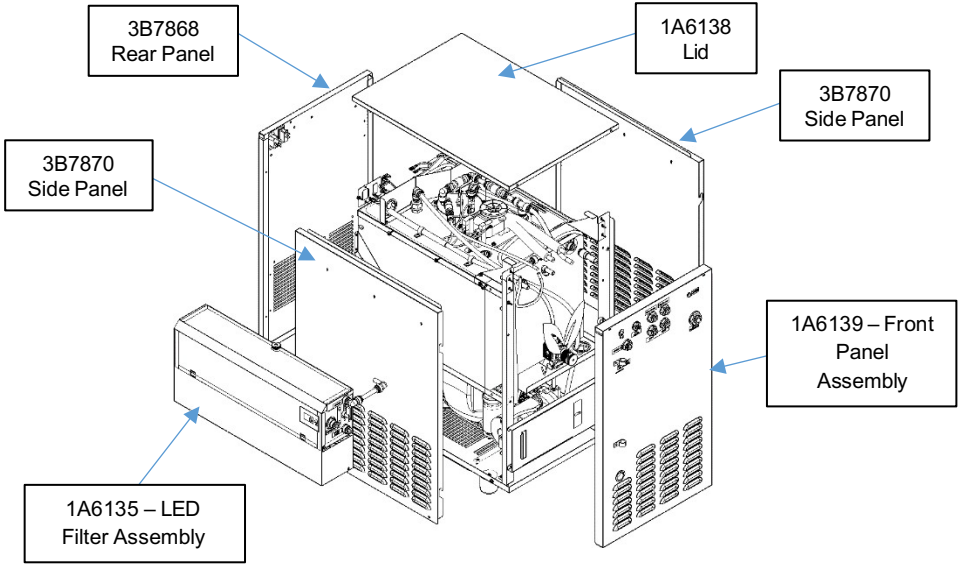

Spare Parts

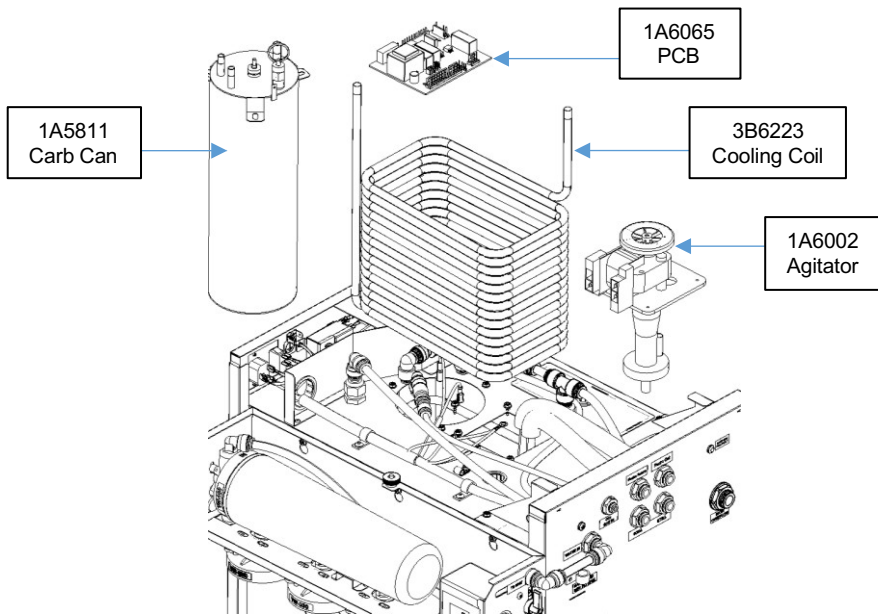

Removal, Transportation and Disposal

Important: Before removal from the installation, ensure all electrical, product and gas connections are disconnected.

Disposal of Scrap Units

It is illegal to simply scrap a refrigeration unit. Before a unit can be scrapped it must first have the gas removed by a specialist using special equipment. Please contact Vero Water for guidance.

Transportation

Important: This unit must be transported in an upright position

As with all refrigeration systems, irreparable damage can be caused by laying the unit on its side or even transporting upside down. Where the unit is transported by a carrier, the carton should always be marked in a conspicuous manner, the correct upright position in which it must be handled.

If a unit has been transported incorrectly it should be placed in the correct upright position and left for 24 hours before attempting to run the system.

Failure to observe the above precautions could seriously damage the system, and would void any warranty.

